

SONICWARE

LIVEN

Lofi-12

User's Manual

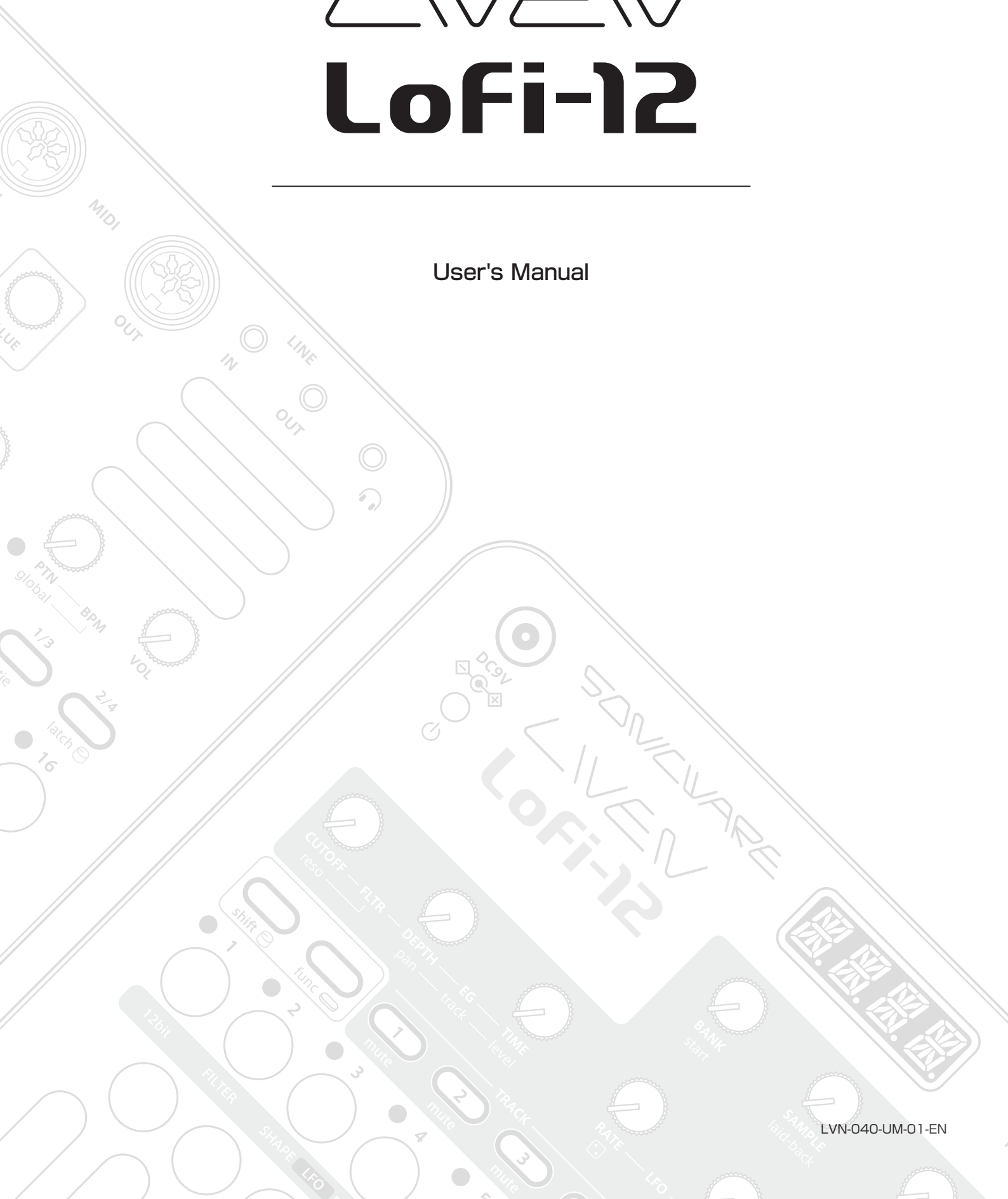

FCC regulation warning (for USA)

Note: This equipment has been tested and found to comply with the limits for a Class B digital device, pursuant to part 15 of the FCC Rules. These limits are designed to provide reasonable protection against harmful interference in a residential installation. This equipment generates, uses and can radiate radio frequency energy and, if not installed and used in accordance with the instructions, may cause harmful interference to radio communications. However, there is no guarantee that interference will not occur in a particular installation. If this equipment does cause harmful interference to radio or television reception, which can be determined by turning the equipment off and on, the user is encouraged to try to correct the interference by one or more of the following measures:

- Reorient or relocate the receiving antenna.
- Increase the separation between the equipment and receiver.
- Connect the equipment into an outlet on a circuit different from that to which the receiver is connected.
- Consult the dealer or an experienced radio/TV technician for help.

Legal disclaimers

Sonicware Inc. (hereafter, "SONICWARE") strives to assure that this document is as accurate and current as possible, but will bear no responsibility for any compensation claims or losses due to content included in this document. Moreover, information in this document could be changed without notice. SONICWARE retains the right to change product specifications and programs at any time. SONICWARE will bear no responsibility for any errors depicted in this document. SONICWARE will bear no responsibility for any losses resulting from the use of this information, functions or performance, regardless of contracts, lack of caution or other conduct.

Copyrights and registered trademarks

- SONICWARE is a registered trademark of Sonicware Inc.
- MIDI is a registered trademark of the Association of Musical Electronics Industry (AMEI).
- Other company names, product names, standard names and registered trademarks in this document are the property of their respective owners.
- All the trademarks and registered trademarks in this document are not intended to violate the copyrights of their owners, but rather are included for the purpose of identification only.
- Recording from copyrighted sources, including audio files, CDs, records, videos, tapes, broadcasts, streamed content and works of art, without permission of the copyright holder for any purpose other than personal use is prohibited by law.
- Sonicware Inc. will not assume any responsibility related to infringements of copyrights.

Important safety precautions

You must read the following precautions in order to use the product safely and prevent accidents.

WARNING: Failure to follow these precautions could result in serious harm to the user or even death.

- Operation using an AC adapter

Do not do anything that could exceed the ratings of outlets and other electrical wiring equipment.

Disconnect the AC adapter from the outlet when lightning occurs and when not using it for a long time.

- Operation using batteries

Use-commercially available 1.5V AA batteries.

Carefully read the precautions of the batteries being used.

Be sure to insert the batteries with +/ – ends oriented correctly.

Do not use new and old batteries together. Do not use batteries of different types together.

Remove the batteries when they will not be used for a long time.

If a leak occurs, thoroughly wipe the battery compartment and battery terminals to remove the leaked fluid.

- Do not open the case and disassemble or modify the product.
- Do not drop, strike or apply excessive force to the unit.
- Do not put liquid on or in the unit.
- Do not put foreign objects into the case.
- Do not use at a loud volume. Doing so could generate loud volumes that might lead to hearing loss.
- When transferring this unit, use the individual packing box and cushioning material that it came with when purchased new.
- When the unit is powered on, do not wrap it in cloth, plastic or other materials.
- Do not step on or apply pressure to the power cord.
- Do not use in the following environmental conditions. Doing so could cause malfunction.

Locations in direct sunlight, environments that exceed 40° C, or near stoves and other heat sources

Locations with extremely low or high temperatures

Locations with extremely high humidity or where the product could become wet

Locations with frequent vibrations or much dust or sand

- If the unit becomes broken or malfunctions, immediately turn the power off and stop using it.

Usage Precautions

Failure to follow these precautions could cause injury to the user and physical damage.

- When connecting cables or working with the power of the unit, minimize the input levels of connected devices or turn them off.
- Cleaning

If the screen or the case become dirty, wipe them gently with a soft cloth.

Do not use chemicals, including alcohol, benzene, thinner or cleansers.

If this does not clean them, wipe them with a slightly damp cloth that has been wrung out well.

Do not turn the power on until the product is completely dry.

Introduction

Thank you very much for purchasing a SONICWARE LIVEN Lofi-12.

The LIVEN Lofi-12 is a compact groovebox that features a retro sampling, including a 12-bit sampler mode that gives any sound a pleasing low-fidelity feel, and a 4-track step sequencer with independent effects for each track as well as a master reverb. The 16 physical knobs enable intuitive operation, while battery power and a built-in speaker make it ready for live performance in any situation.

We hope you enjoy using it for many years.

Key features of the LIVEN Lofi-12

- **Retro sampling** gives any sound a lo-fi vibe
- Sampled sounds are automatically assigned to the keyboard and can be played with different pitches
- Powerful **4-track step sequencer** developed with the LIVEN series
- The **Laid-back knob** can delay sound timing for a the drunk beats
- **11 types** of effects independent for each track along with **8 types** of master effects

Jam in any situation

Battery power and a built-in speaker enable producing and performing anywhere

Synchronize with all kinds of devices

Clock synchronization is possible with devices that have MIDI or SYNC connectors.

The audio SYNC function enables synchronization with Teenage En-

Key features of the LIVEN Lofi-12

gineering Pocket Operator devices using the LINE jack.

In addition, clock synchronization signals can be bridged between different connectors. For example, MIDI clock can be generated from an input SYNC clock signal.

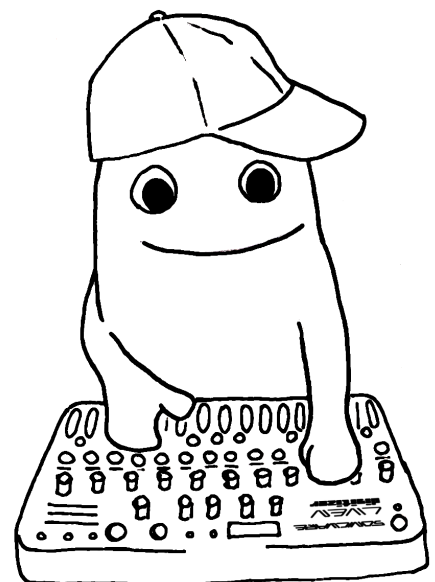

Contents

Names of parts	10	Changing the arpeggiator type (in ARP mode)	22
Connection example	10	Sample selection	23
Starting up and shutting down	11	Overview	23
Preparing a power supply	11	Selecting samples	23
Starting up	11	12-bit sampler mode	23
Turning the unit off	11	Changing the pitches of samples	24
Basic operations	12	Changing track pitch	24
Adjusting the overall volume	12	Changing track pitch by semitone (transposing)	24
Turning on/off the speaker	12	Adjusting how samples sound	25
Using the func button	13	Adjusting sample start positions	25
Using the shift button	13	Adjusting sample attack and release	25
Using the shift button hold function	13	Filters	26
Tracks and patterns	14	Changing the filter type	26
Track overview	14	Changing the filter cutoff frequency	27
Pattern overview	14	Adjusting the filter resonance	27
Patterns and banks	14	Adjusting the filter envelope	28
Basic pattern operation	15	LFO	29
Selecting patterns	15	Overview	29
Playing patterns	15	Adjusting the LFO speed	29
Selecting pattern 17 and higher	15	Adjusting the amount of LFO effect on pitch	29
Changing the tempo	16	Adjusting the amount of LFO effect on filter cutoff	29
Reloading patterns	16	Sweep	30
Pattern chain playback	17	Overview	30
Selecting multiple patterns and playing them in order (chain playback)	17	Sweeping notes while playing	30
Adjusting the volume of individual patterns	17	Effects	31
Track selection and basic adjustments	18	Adjusting effects	31
Selecting tracks	18	Reverb	32
Muting tracks	18	Adjusting the reverb	32
Adjusting track levels	18	Quick sampling - Recording	33
Adjusting track panning	18	Connecting equipment to the LINE IN	33
Performing with the keyboard and voice modes	19	Select the recording slot	33
Performing	19	Enable recording	33
Holding keyboard notes	19	Start recording	33
Changing the velocity	19	Sampling settings	34
Changing the octave range	20	Setting auto recording	34
Changing the voice mode	20	Setting the sampling frequency	34
Changing the glide (in MONO/LEGATO mode)	21	LINE IN settings	35
		Changing the gain	35

Contents

Setting mono/stereo	35	Importing sample banks	46
Activating and deactivating		Step sequencer overview	47
SAMPLE & EDIT mode	36	Overview	47
Activating SAMPLE & EDIT mode (slot selection)	36	Lofi-12 step sequencer features	47
Selecting slots	36	Creating sequences - Preparation ..	48
Activating and deactivating		Selecting tracks and setting sounds...	48
SAMPLE & EDIT mode	37	Creating sequences - Settings	49
Deactivating SAMPLE & EDIT mode (returning to Regular mode)	37	Setting the note length of one step ..	49
SAMPLE & EDIT mode (editing)		Changing the sequence length.....	49
— Preparing to record	38	Creating sequences	
Connecting equipment to the LINE IN	38	- Step recording	50
Select the recording slot	38	Basic operations	50
SAMPLE & EDIT mode (editing)		Selecting steps 17 and higher	51
— Recording	39	Clearing steps	52
Enable recording	39	Copying steps	52
Set the sample quality	39	Automatically advancing steps during step recording (Auto Step mode)	52
Start recording	39	Enabling tied-note (long sound) input ..	53
SAMPLE & EDIT mode (editing)		Inputting tied-notes (long sounds)	53
— Basic operation	40	Creating sequences	
Adjust parameters	40	- Real-time recording	54
Adjust parameters precisely	40	Basic operations	54
Save settings	40	Clearing notes	54
Discard settings	40	Setting the metronome	55
Setting Sustain loops	41	Setting a pre-count	55
Reversing sample playback	42	Creating sequences	
Setting sample fade out	42	- Direct recording	56
Chacking the attack, release, and velocity of the sound	42	Basic operations	56
SAMPLE & EDIT mode (editing)		Creating sequences	
— Renaming and copying	43	- Groove settings	58
Renaming samples	43	Setting the swing	58
Copying samples	43	Setting the laid-back function	58
SAMPLE & EDIT mode (editing)		Parameter locking	59
— Clearing	44	Basic parameter locking	
Clearing samples	44	operations	59
SAMPLE & EDIT mode (editing)		Turning parameter locking on	59
— Exporting/importing samples	45	Clearing parameter lock data.....	59
Exporting a single sample	45	Parameter locking - Direct input	60
Importing a single sample	45	Turning parameter locking on	60
Exporting sample banks	46	Recording knob operations	60
		Parameter locking	
		- Real-time input	61

Contents

Inputting in real time (parameter recording)	61
Parameter locking	
- Sound locking input	62
Turning sound locking on	62
Recording note input and parameter lock data at the same time	62
Sequence effects	63
Random	63
Random settings	63
Dice	63
Stutter	64
Deleting sequences	65
Clearing steps	65
Clearing all note data in a sequence ..	65
Restoring only track sounds to the last saved state	65
Copying tracks	66
Copying tracks	66
Pattern saving	67
Saving patterns	67
Initializing patterns	67
Pattern renaming	68
Renaming patterns	68
Tempo overview	69
Setting the BPM mode	69
Setting the pattern BPM	69
Setting the global BPM	70
Clock synchronization with external devices — Clock settings ..	71
Overview	71
Setting the clock source	72
Setting Audio Sync output	72
Setting SYNC IN polarity	73
Setting SYNC OUT polarity	73
Clock synchronization with external de- vices — Connection examples	74
Lofi-12 as clock master	74
External device as clock master	75
Bridging clock signals to a different con- nector from an external device acting as the clock master	76
MIDI	77
Setting channels for transmitting and re- ceiving MIDI	77
Setting the MIDI channel for pattern pa- rameters	77
Setting the MIDI channel for accessing the selected track (automatic channel) ..	77
Setting the MIDI channel used to output keyboard playing	78
Turning control change transmission on/off	78
Turning MIDI clock output on/off	78
Setting MIDI OUT	79
Setting MIDI command transmitting and receiving	79
Turning active sensing transmission on/off	79
Turning on/off active sensing reception	80
Setting the channel for transmitting and receiving program changes	80
Turning on/off program change transmis- sion	80
Turning on/off program change reception	81
Exporting/importing user data	82
Connecting - Exporting/importing to/from a PC/Mac	82
Connecting - Exporting/importing to/from another Lofi-12	82
Exporting a single pattern	83
Importing a single pattern	83
Backing up all user data at once	84
Restoring (importing) user data	85
System settings	86
Setting the battery type	86
Setting the automatic power down func- tion	86
Setting the headphone gain	87
Setting the master tuning	87
Setting knob movement behavior	88
Restoring to factory default settings (fac-	

Contents

tory reset)	89
Checking the system versions	89
Updating the firmware	90
Error codes.....	91
Appendix	92
Figure1. Sound architecture.....	92

Names of parts

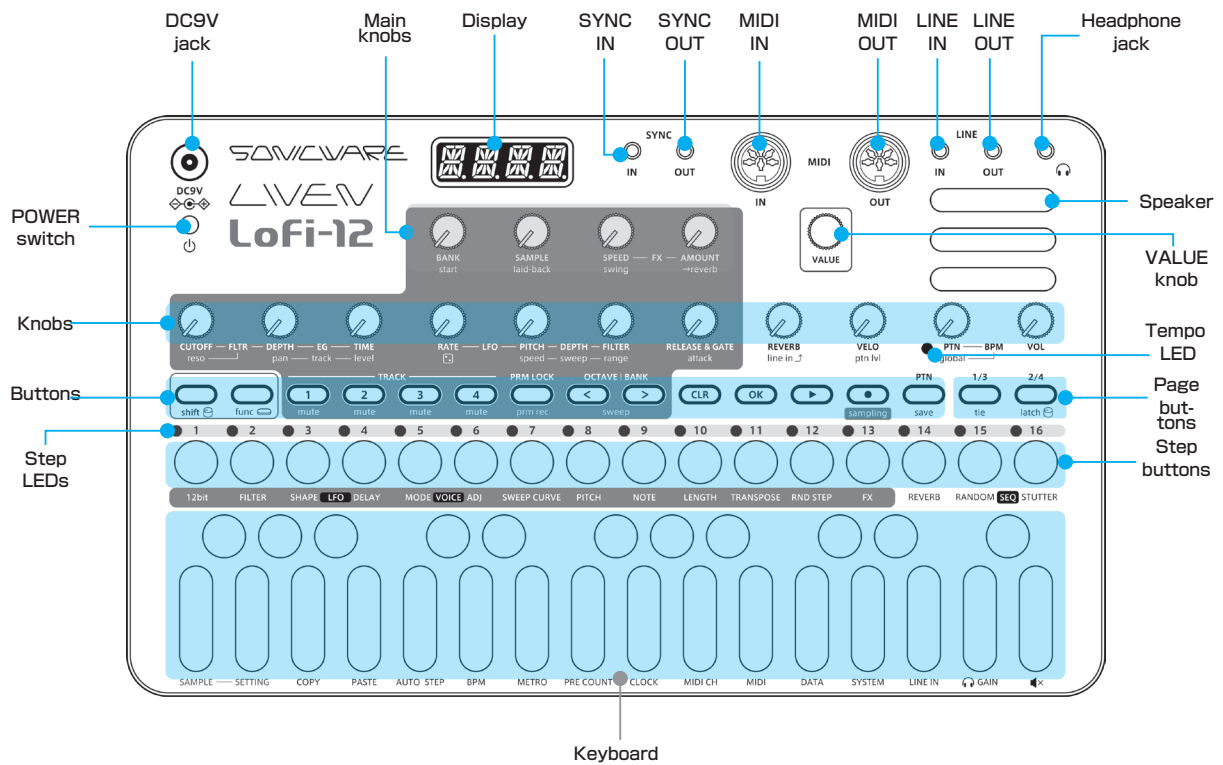

Connection example

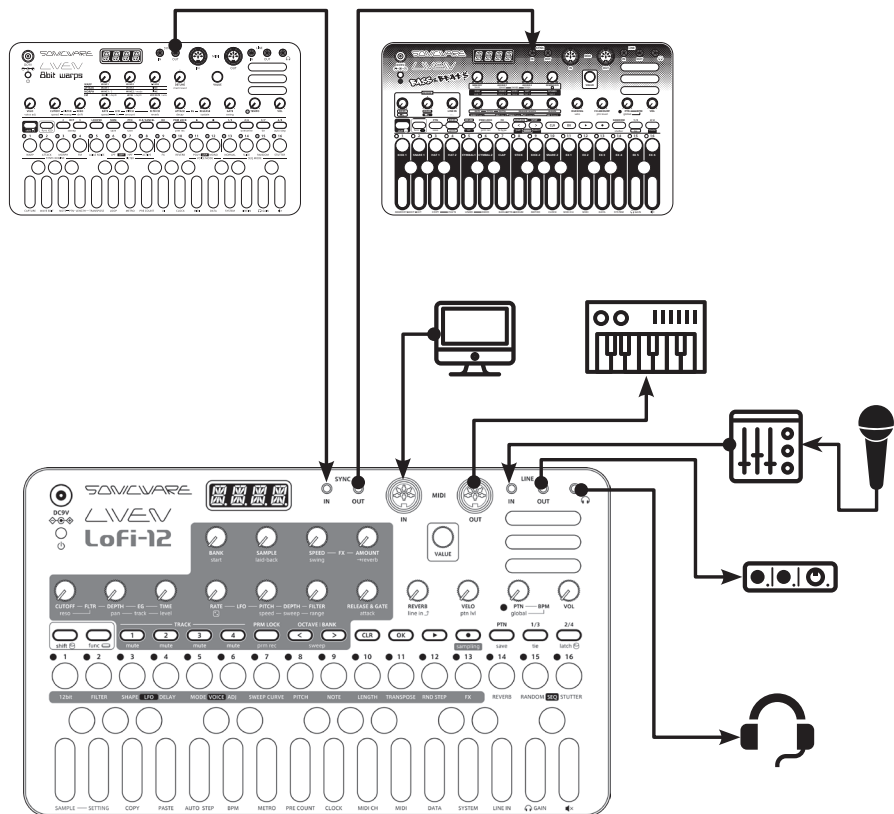

Note: Use connection cables that are 3 m or shorter.

Starting up and shutting down

Preparing a power supply

AC adapter (sold separately)

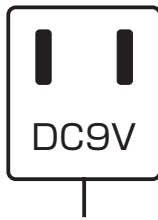

or

6 AA batteries

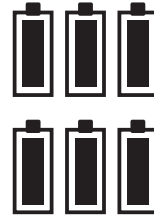

Only use AC adapters that conform to the specifications. Using an AC adapter with different specifications could cause damage.

AC adapter specifications*

Voltage: 9V output
Current: 1A or higher
Connector: EIAJ-03 compliant
(1.7mm inner diameter,
4.75mm outer diameter)

Polarity: center+

*Equivalent to Korg Volca KA350 adapter

BT.LO will appear on the display if the remaining battery charge is low. Replace the batteries immediately.



When using nickel-metal hydride batteries or lithium batteries, change the battery setting.

(→ P. 86)

Starting up

- 1 Press and hold the POWER switch until LOFI (LIVEN **Lofi-12**) appears on the display.



Turning the unit off

- 1 Press and hold the POWER switch until the display turns off.



! Recently made changes will be lost when the unit is turned off. Save the changes if necessary.

Basic operations

This section explains basic operations.

Adjusting the overall volume

The volume from the speaker, headphones and the LINE OUT can be adjusted.



Volume
0 - 127
This can be adjusted from $-\infty$ to +6 dB with 0 dB as the middle value (63-64).

Turning on/off the speaker

The built-in speaker can be turned off manually if you want to mute it without connecting headphones (when only using the LINE OUT, for example).





Speaker	
MUTE	Speaker off
SPK	Speaker on

Basic operations

Using the func button

Some Lofi-12 buttons have two functions.



In the example above, the secondary functions of the  and  buttons are “save” and “FX” .

Pressing these buttons while pressing the  button will activate their secondary functions.

In this manual, operations while pressing the  button will be shown as follows.



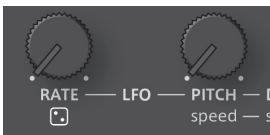

Using the shift button

Many Lofi-12 knobs have both **uppercase** and **lowercase** names.





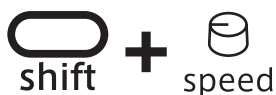

Turning a knob alone will adjust the uppercase parameter.

Turning the knob while pressing the  button will adjust the lowercase parameter.

In this manual, operations while pressing the  button will be shown as follows.



Using the shift button hold function

By pressing the  button while pressing the  button, the  button hold function can be activated. (The button lights orange.) When the hold function is activated, lowercase parameters can be adjusted without pressing the  button.

Press the  button again to deactivate the hold function.

Tracks and patterns

Track overview

The LIVEN Lofi-12 groovebox has a 4-track sequencer. **Tracks** contain both **sound** settings and **sequences** (performance data). The four tracks of the LIVEN Lofi-12 can each have different sounds and individual sequences created for them.

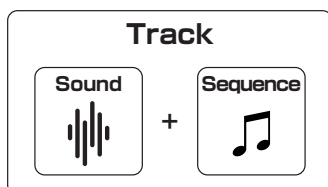

Pattern overview

A **pattern** is a combination of the four tracks described above. With lengths of 1–4 bars, patterns can be used as the smallest units in making songs.

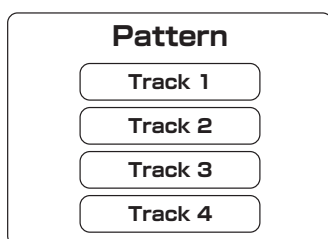

Patterns and banks

16 patterns can be stored together in a single **bank**. The LIVEN Lofi-12 has 4 banks enabling 64 patterns to be saved in total.

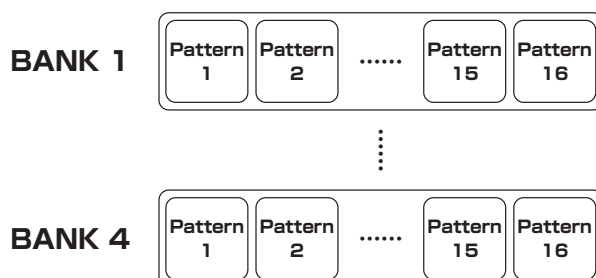

- BANK 1 contains present patterns. Following the instructions

Basic pattern operation

Selecting patterns

1 Press **PTN**.

2 Press $\frac{1}{16}$ - $\frac{16}{16}$.

→ This selects a pattern.

(STEP 1 for pattern 1... STEP 16 for pattern 16)

Playing patterns

3 Press **▶**.

Press it again to stop.

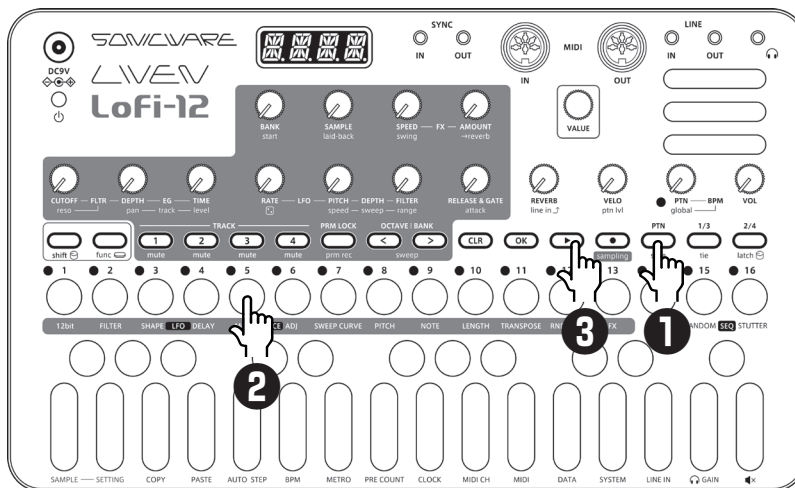

Selecting pattern 17 and higher

Press **OCTAVE | BANK** after procedure 1 to change the bank, enabling selection of pattern 17 and higher.



- If a different pattern is selected during pattern playback, it will be readied but will not start playing immediately. Playback will switch to the selected pattern after the playing pattern completes.
- After pressing **PTN**, **VALUE** can also be used to select patterns.

Basic pattern operation

Changing the tempo



PTN - BPM

40 - 250

When the tempo is shown on the display, the  VALUE knob can be turned to change it in 0.1-beat increments.

Reloading patterns

1 Press .







2 Press .

This is useful for restoring sounds to their original states during live performances, for example.



Pattern chain playback

Selecting multiple patterns and playing them in order (chain playback)

- 1 Press  twice (lights orange).
- 2 Press  - .
Select patterns in the order that you want them to play.
Press  -  again to deselect.
- 3 Press .
The patterns will play in the selected order.



- Press  again to end chain playback.
 - Stutter mode (→ P. 64) cannot be used during chain playback.
-

Adjusting the volume of individual patterns

- 1 Turn  + .

Pattern Level
0 - 127
Pattern levels can be set in a range of $-\infty$ - +6 dB.

Track selection and basic adjustments

Switch between the 4 tracks of the Lofi-12 to work with them.

Selecting tracks

- 1 Press for the track you want to select.

The selected TRACK button will light red and its track number will be shown on the display. (The unselected TRACK buttons will light green.)

The parameters shown in the dark gray areas on the top of the unit can be controlled separately for each track.

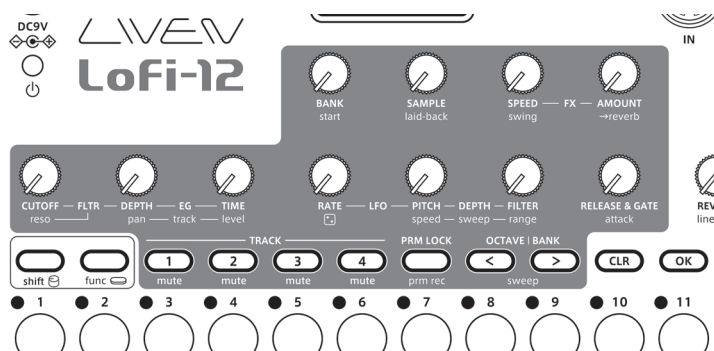

Muting tracks

- 1 Press + for the track you want to select.



The muted TRACK buttons will light orange.

Press + the button that is lit orange to unmute the track.

Adjusting track levels

- 1 Turn + .

The level of the selected track can be set in a range of 0 - 127 (-∞ - +6 dB).

Adjusting track panning

- 1 Turn + .

The panning of the selected track can be set in a range of L63 - CNTR - R63.

Performing with the keyboard and voice modes

Performing

- 1 Play the keyboard.

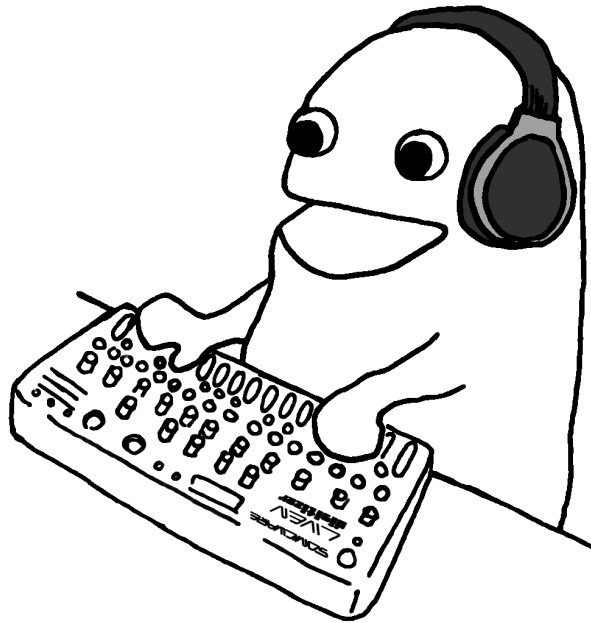

Holding keyboard notes

- 1 Press **OK** + keys to hold them.



- Press the same key again to stop holding it.
 - Press **CLR** + **OK** to stop holding all keys.
-

Changing the velocity



The velocity value used when playing keys can be set.

















Velocity
0-127
The higher the value, the louder the notes will be played.



Performing with the keyboard and voice modes

Changing the octave range

- 1 Press  / .
This lowers/raises the range by an octave.

		+3 oc-
		+2 oc-
		+1 oc-
		
		- 1 oc-
		- 2 oc-
		- 3 oc-

Changing the voice mode

- 1 Press  + .
This selects the voice mode

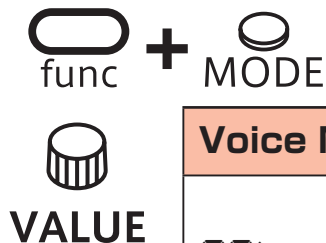



Voice Mode		
<i>POLY</i>	Polyphonic	Up to 10 voices can be output simultaneously in this mode
<i>MONO</i>	Monophonic	In this single voice mode, each note re-triggers the sound.
<i>LGT</i>	Legato	In this single voice mode, notes do not re-trigger the sound.
<i>ARP</i>	Arpeggiator	Pressed keyboard keys are played one at a time in this mode.

Performing with the keyboard and voice modes

Changing the glide (in MONO/LEGATO mode)

1 Press  + .

2 Use  VALUE to set the speed.

 + 
func + ADJ

VALUE

Glide
0 - 127
The time can be changed in a range of 0 - 10000 ms.

Performing with the keyboard and voice modes













Changing the arpeggiator type (in ARP mode)

1 Press  + .

2 Use  VALUE to select the arpeggiator type.

 + 



VALUE

Arpeggiator		
<i>UP</i>	UP	
<i>DOWN</i>	DOWN	
<i>U.D</i>	UP DOWN	
<i>DU</i>	DOWN UP	
<i>U&D</i>	UP & DOWN	
<i>DU&U</i>	DOWN & UP	
<i>RNDM</i>	RANDOM	
<i>UP+1</i>	UP +1	
<i>UP+2</i>	UP +2	
<i>DN-1</i>	DOWN - 1	
<i>DN-2</i>	DOWN - 2	
<i>PO</i>	PLAY ORDER	 Notes are sounded in the order played on the keyboard

Sample selection

Overview

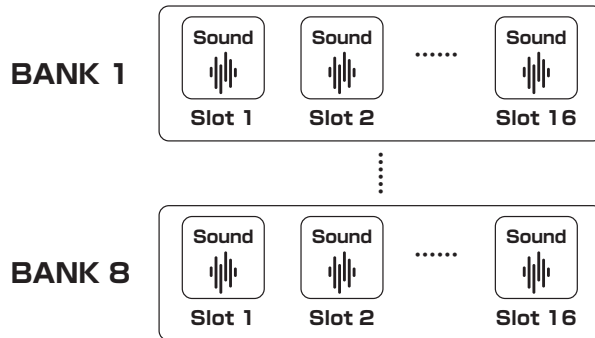
The Lofi-12 can store a total of 128 recorded samples in 8 banks with 16 slots each.



Selecting samples

- 1 Turn \odot BANK and \odot SAMPLE to select samples. Sounds can be checked by playing the keys on the keyboard.

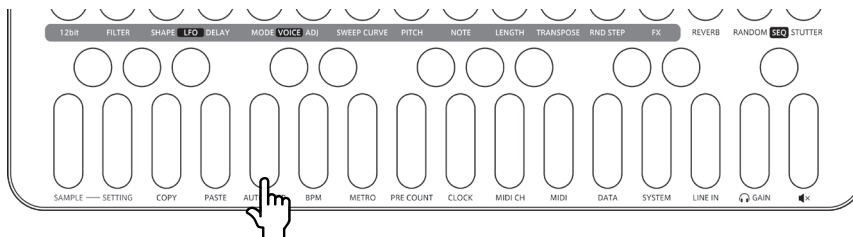

Play this key to hear the sample with its original pitch and length.

12-bit sampler mode



The Lofi-12 records samples at 16-bit/12kHz or 16-bit/24kHz, but it also has a mode that drops the bit rate to 12-bit and re-create the sound of vintage samplers.

- 1 Press \odot_{func} + \odot_{12bit} . Turning this on enables 12-bit sampler mode.

Changing the pitches of samples

In addition to changing pitches in semitones using the keyboard keys, the Lofi-12 has other ways of changing pitches.



Changing track pitch

- 1 Press  +  .
Press this button to change the pitch 100 cents (1 semitone) at a time from - 600 - +600.
Use  VALUE to adjust it 1 cent at a time.



- Each sample pitch can be changed in SAMPLE & EDIT mode.
(→ P. 40)
-

Changing track pitch by semitone (transposing)

- 1 Press  +  .
Use  VALUE to change the pitch in a range of - 12 - +12 semitones.



- If the key is changed during pattern playback, the actual change of key will occur the next time the pattern begins.
-

Adjusting how samples sound

Adjusting sample start positions

- 1 Turn  +  .
The sample start position can be set from 0 - 127.

Adjusting sample attack and release

Use the envelope generator to adjust the attack that affects the beginning of the sound and the release that affects how the sound fades out.

- 1 Turn  +  or  .



attack (EG)

0 - 127

The attack time can be changed in a range of 0 - 4000 ms.



RELEASE & GATE

RELEASE & GATE (EG)

0 - 127

The release time can be changed in a range of 0 - 4000 ms.

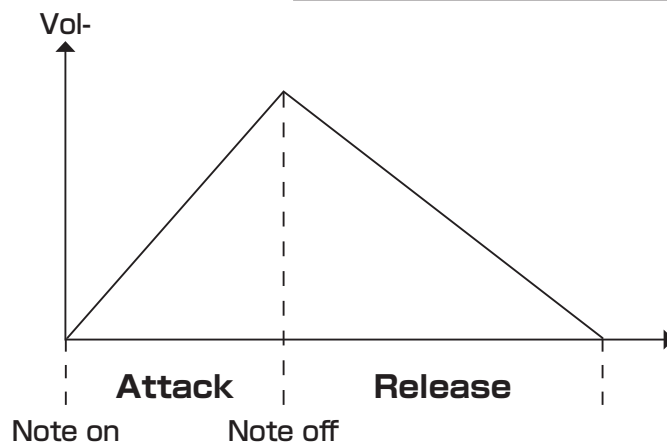

Filters

Changing the filter type

1 Press  +  to select the type.



Filter type		
LPF.^	<i>LP ^</i>	This filter cuts high frequencies using an envelope with attack and decay.
LPF. _	<i>LP _</i>	This filter cuts high frequencies using an envelope with decay.
LPF./ _	<i>LP / _</i>	This filter cuts high frequencies using an envelope with attack.
HPF.^	<i>HP ^</i>	This filter cuts low frequencies using an envelope with attack and decay.
HPF. _	<i>HP _</i>	This filter cuts low frequencies using an envelope with decay.
HPF./ _	<i>HP / _</i>	This filter cuts low frequencies using an envelope with attack.
BPF.^	<i>BP ^</i>	This filter only allows frequencies in a specific range to pass using an envelope with attack and decay.
BPF./	<i>BP / </i>	This filter only allows frequencies in a specific range to pass using an envelope with decay.
BPF. ^	<i>BP ^</i>	This filter only allows frequencies in a specific range to pass using an envelope with attack.

Filters

Changing the filter cutoff frequency



Cutoff
0 - 127
The cutoff frequency can be changed in a range of 70 - 21600 Hz.

Adjusting the filter resonance



Resonance
0 - 127
The resonance can be changed in a range of 0.1 - 10.
For BPF, the bandwidth can be changed in a 0.1 - 2.0 octave range.

Filters

Adjusting the filter envelope

DEPTH – EG

Filter EG Depth
– 63 – 63
The envelope depth can be set from – 100 – 100%.

TIME – EG

Filter EG Time
0 – 127
The time can be changed in a range of 13 ms – 20 s.

For LPF.^, HPF.^ and BPF.^, TIME changes the attack and the decay.

For LPF.!_, HPF.!_ and BPF.!_, TIME changes the decay.

Filters of the same type (e.g. LPF.^ and LPF.!_) share DEPTH and TIME settings.

LFO

Overview

Each track of the Lofi-12 has one **LFO** that can be used to modulate the pitch and the cutoff frequency.

Adjusting the LFO speed

RATE — LFO

Rate - LFO
0 - 127
The frequency of the LFO can be changed in a range of 0 - 30 Hz.

Adjusting the amount of LFO effect on pitch

LFO — PITCH

Pitch Depth - LFO
0 - 127
This changes it in a range of 0 - 2 octaves.

Adjusting the amount of LFO effect on filter cutoff

FILTER — DEPTH

Filter Cutoff Depth - LFO
0 - 127
The higher the value is, the greater the amount of change. Set to 0 for no change.

Sweep

Overview

The Lofi-12 has a sweep sound function that changes the pitch at a set speed.

Sweeping notes while playing

1 Press + / .



Sweep	
	Sweep down
	Sweep up

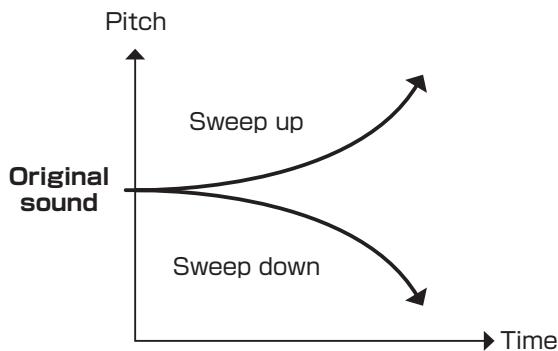



• Press + / again to disable the sweep function.

+ - sweep	+ - sweep	+ SWEEP CURVE	
Speed	Range		Curve
Sweep speed	Sweep amount		Curve type
0-31 The higher the value is, the slower the speed becomes.	1-11	1 - 11 semi-tones	LINE Linear After input, the note changes linearly to the range amount.
	1OCT	1 octave	EXP Exponential After input, the note changes gradually at first and then rapidly in the latter half until it reaches the range amount.
	2OCT	2 octaves	LOG Logarithmic After input, the note changes rapidly at first and then gradually slows until it reaches the range amount.





Effects

Effects can be set for each track of the Lofi-12.

Adjusting effects

1 Press  +  to select an effect.

2 Use  SPEED - FX and  AMOUNT - FX to adjust the parameters.

 + 		 SPEED - FX	 AMOUNT - FX
OFF	Off	---	---
CHRS	Chorus	Rate	Amount
FLNG	Flanger	Speed	Amount
DLY	Delay	Time	Amount
CRSH	Crush	Sample rate	LPF cutoff
DIST	Distortion	Gain	Tone
LPF	Low pass filter	Cutoff	Resonance
HPF	High pass filter	Cutoff	Resonance
ISO	Isolator	Frequency	Balance
TILT	Tilt EQ	Frequency	Balance
TAML	Tremolo	Rate	Amount
COMP	Compressor	Ratio	Threshold



- In step 1,  VALUE can also be used to select the effect type.

Reverb

The Lofi-12 has a single high quality reverb effect.



The send levels for this reverb can be set individually for each track.



Adjusting the reverb

1 Press  +  to select the effect.

2 Use  REVERB to adjust the parameter.

VALUE

	 + 	 REVERB
OFF	Off	----
HALL	Hall	Mix
ROOM	Room	Mix
ARNA	Arena	Mix
PLAT	Plate	Mix
TNNL	Tunnel	Mix
INF	Infinity	Mix
TAPE	Cassette Tape Simulator	Noise + wow flutter
VNYL	Vinyl Simulator	Noise + wow flutter

3 Use  +  to set the reverb send level for individual tracks.

Use  +  to set the reverb send level for LINE IN input.

Quick sampling – Recording

Connecting equipment to the LINE IN

Enable recording

- 1 Connect the output of the equipment you want to record to the Lofi-12 LINE IN.



- Mics and guitars cannot be connected directly. Use a mixer or other equipment to convert their outputs to line signals.

- 3 Press **func** + **sampling**.
sampling will blink red.
Use the step keys to check the recording level.

Start recording

- 4 Press **sampling** again.
sampling will light red and recording will automatically start when a signal is input.



The step keys show the recording progress.
When step 16 lights, recording will stop automatically.

Select the recording slot

- 2 Use **BANK** and **SAMPLE** to select the slot where the sample will be recorded.

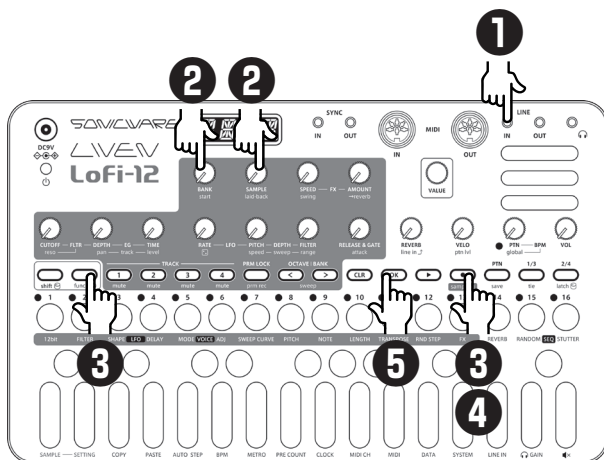

- 5 Press **OK** twice.
This saves the sample.





- Press **CLR** to cancel the operation.
- Use **SAMPLE & EDIT** mode to rename and edit samples.
(→ P. 36)

Sampling settings

The following settings are used for quick sampling.

Setting auto recording

1 Press  +  to select A.R.LV. 

2 Turn  VALUE.

This can be set to OFF or the input signal level that starts recording automatically (– 60 – – 20 dB).

If auto recording is off, press  when in recording standby to start recording.

Setting the sampling frequency

1 Press  + , and select S.FRQ 12K or 24K.

2 Turn  VALUE to select one.

Sample quality	Sampling frequency	Maximum recording time
Lofi	12 kHz	4 seconds
Standard	24kHz	2 seconds



- Use func + LINE IN to adjust the LINE IN input gain.
 - After recording completes, the volume of the sample will be normalized automatically.
-

LINE IN settings

Changing the gain

1 Press  +  to select GAIN.

GAIN

2 Turn  VALUE to change the gain.

VALUE

Gain
MUTE - 127

Setting mono/stereo

1 Press  +  to select MONO.

MONO

2 Turn  VALUE to switch between ON and OFF.

VALUE

Monophonic	
ON	Mono
OFF	Stereo

Activating and deactivating SAMPLE & EDIT mode

Activating SAMPLE & EDIT mode (slot selection)

1 Press **func** + **SAMPLE**.

Selecting slots

2 Turn **VALUE** to select a slot and press **OK**.
→ This activates SAMPLE & EDIT mode (editing).

3 Press **OK**.

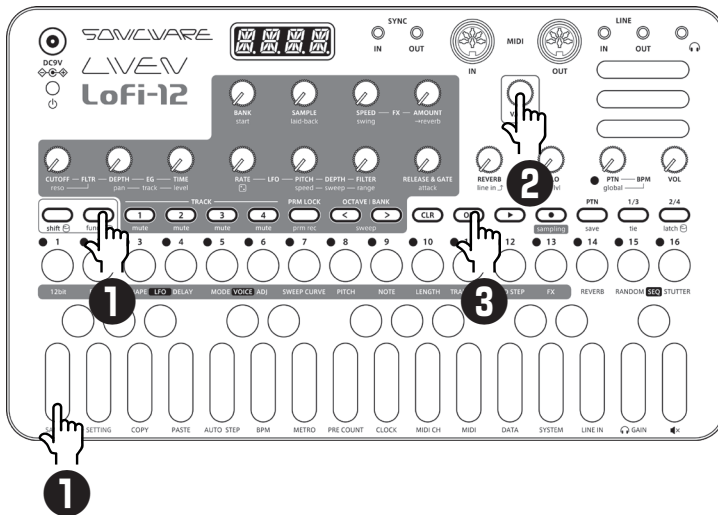
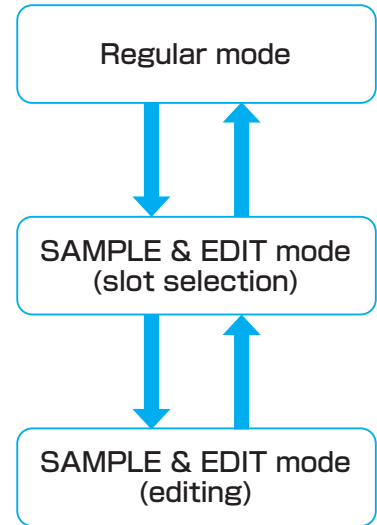

Place the included SAMPLE & EDIT overlay on the unit.



- When a slot is selected, the sample can be auditioned by playing the keyboard.

Activating and deactivating SAMPLE & EDIT mode

Deactivating SAMPLE & EDIT mode (returning to Regular mode)

- 1** Press  .
This returns to slot selection.

- 2** Press  again.
This returns to regular mode.

SAMPLE & EDIT mode (editing)

— Preparing to record

Connecting equipment to the LINE IN slot

1 Connect the output of the equipment you want to record to the Lofi-12 LINE IN.



- Mics and guitars cannot be connected directly. Use a mixer or other equipment to convert their outputs to line signals.
- The Lofi-12 records in mono. Stereo signals input to the LINE IN are mixed in mono by default.

Select the recording slot

2 In SAMPLE & EDIT mode, press **CANCEL CLR**.
SELECT will light red.



3 Turn **VALUE** to select the slot where you want to record the sample.



- When a slot is selected, the sample can be auditioned by playing the keyboard.

4 Press **OK → EDIT** to enable editing.
EDIT will light red.

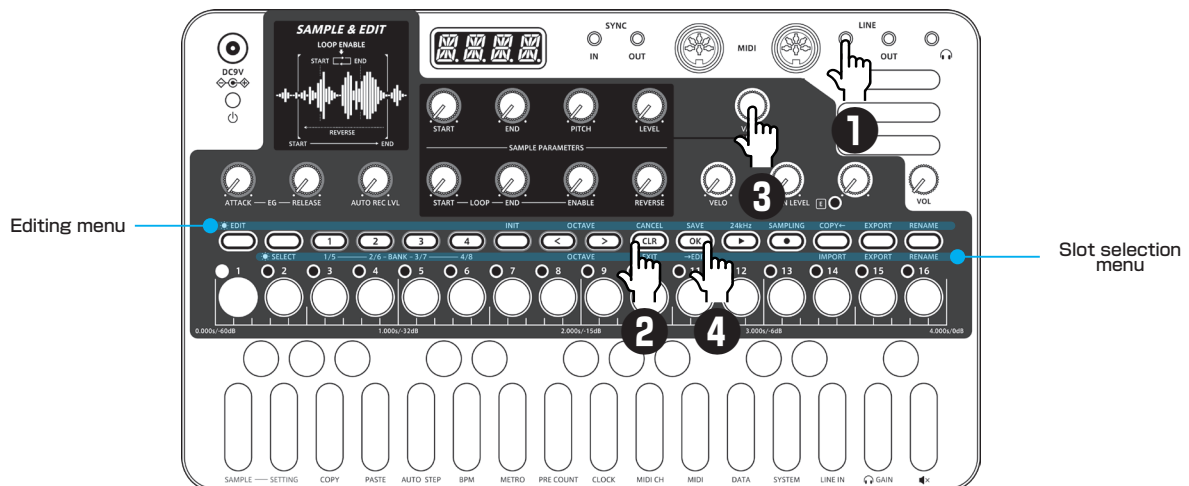

SAMPLE & EDIT mode (editing)

— Recording

Enable recording

- 1 Press **SAMPLING**.
It will blink red.
Use the step keys to check the recording level.

Press **CANCEL CLR** to cancel.



- Use **LINE IN LEVEL** to adjust the input level.

Start recording

- 3 Press **SAMPLING** again.
It will light and automatically start recording when a signal is input.



The step keys show the recording progress.

When step 16 lights, recording will stop automatically.

- 4 Press **SAVE OK** twice.
This saves the sample.



- **AUTO REC LVL** can be set to OFF or the input signal level that starts recording automatically (–60 – –20 dB).

If **AUTO REC LVL** is OFF, pressing **SAMPLING** will start recording.

- After recording completes, the volume of the sample will be normalized automatically.

Set the sample quality

- 2 Press **24kHz** to select the sampling frequency.

When **24kHz** is lit red, the setting is 24kHz (2 seconds of recording). When it is unlit, the setting is 12kHz (4 seconds of recording).

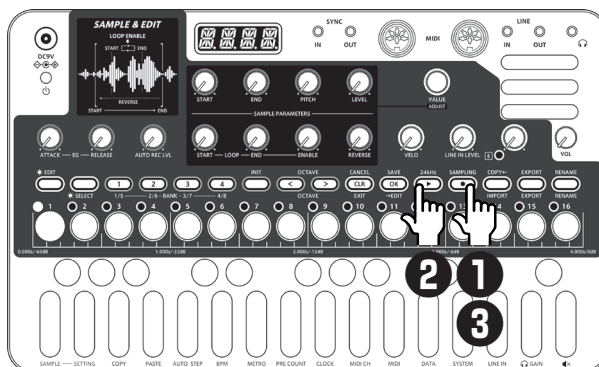

SAMPLE & EDIT mode (editing)







— Basic operation

Adjust parameters

1 Turn a knob.

Adjust parameters precisely

2 Turn  VALUE while the parameter is shown.

 START	 END	 PITCH	 LEVEL
Start	End	Pitch	Level
Start position in sample	End position in sample	Pitch adjustment	Level
0 - 9998	1 - 9999	- 999 - +999*	0 - 127
 VALUE	 VALUE	 VALUE	

 VALUE Parameters that allow precise adjustment
*100 = 1 semitone

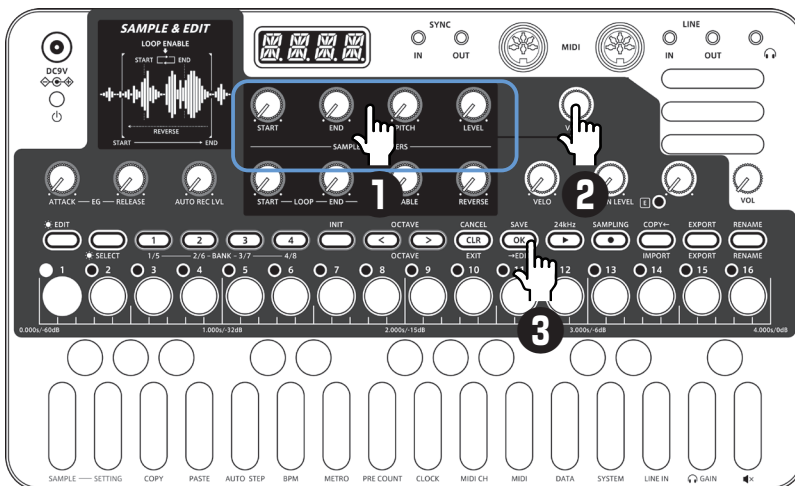

Save settings

3 Press  twice.
It will be saved and return to slot selection.



Discard settings

Press  .
This will return to slot selection without saving.

SAMPLE & EDIT mode (editing)





— Basic operation

Setting Sustain loops

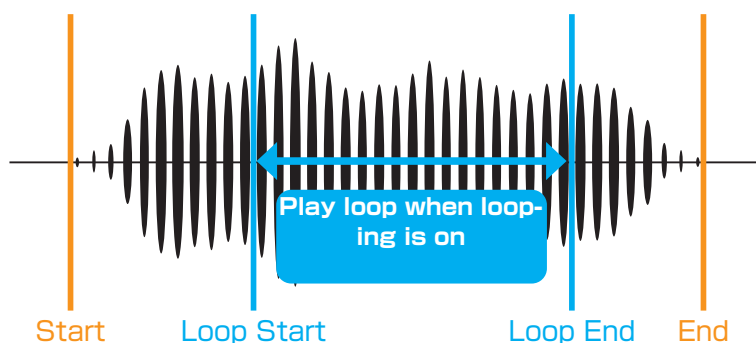
The Lofi-12 has a sustain loop function that can play the desired interval in a sample as a loop.

Set a sustain loop if you want to have a sound play continuously like an organ as long as you press a key on the keyboard.



 START - LOOP	 END - LOOP	 ENABLE
Loop Start	Loop End	Loop Enable
Start position of sustain loop	End position of sustain loop	Sustain loop activation
0 - 9776	420 - 9999	ON/OFF
Set the position of the 9,999 divisions of the sample in increments of 100.	Set the position of the 9,999 divisions of the sample in increments of 100.	This turns the sustain loop on/off.
 VALUE	 VALUE	
Adjust the position in increments of 1.	Adjust the position in increments of 1.	

The Loop Start and Loop End are connected by a crossfade.

Set an interval that does not have volume or tone changes in order to make the loop sound natural. Setting a natural-sounding sustain loop might not be possible for some waveforms.

SAMPLE & EDIT mode (editing)

— Basic operation

Reversing sample playback



Reverse	
This turns reverse playback on/off.	
OFF	Played in regular direction
ON	Played in reverse

Setting sample fade out

The entire length of a sample is shown by the lit \circ - \circ .

- 1 Press the step at the position where you want to start the fade-out.
For example, press \circ if you want to start to fade out in the middle of the sample.
Steps will blink for the length that is being faded out.

Press \circ to set no fadeout.

- 2 Press \circ twice.
This applies the fadeout to the sample.



- Fade-outs can only be set when LOOP ENABLE is off.
-

Chacking the attack, release, and velocity of the sound



 ATTACK – EG	 RELEASE – EG	 VELO
Time for sample to reach full volume after note is turned on	Time until sample becomes silent after note is turned off	Volume triggered when note is turned on
0-127	0-127	0-127

SAMPLE & EDIT mode (editing)

— Renaming and copying

Renaming samples

1 In editing mode, press .

2 Use  and  to move the cursor left and right, and turn  to select characters.

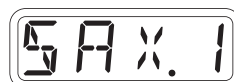

3 Press .
This completes the setting.
DONE will appear on the display.



- During slot selection,  can be pressed to rename a bank in the same way.
-

Copying samples

1 Use slot selection to select an empty slot



2 Press  to enable editing.

3 Press .

4 Turn  to select the sample you want to copy.

5 Press .
The sample will be copied and
DONE will be shown on the display.



- After completing a procedure, press  twice to save the changes.
 - Press  during a procedure to cancel it.
-



SAMPLE & EDIT mode (editing)

— Clearing

Clearing samples

- 1 In editing mode, press .
This clears the sample.



- After completing a procedure, press  twice to save the changes.
 - Press  during a procedure to cancel it.
-

SAMPLE & EDIT mode (editing)

— Exporting/importing samples

Recorded samples can be exported to or imported from a PC, Mac or similar device by MIDI. See page 81 for details about connection.

Exporting a single sample

1 Use slot selection to select the sample you want to export.

2 Press  to enable editing.

3 Press .



4 Set your PC to receive MIDI data.

5 Press .

This starts sample data transmission.



The step LEDs will show the progress. When finished, DONE will appear on the display.

Importing a single sample

1 Use slot selection to select the slot you want to import to.

2 Press  to enable editing.





3 Start transmitting data from the transmitting device.

4 After receiving data has completed, press  twice to save it.

SAMPLE & EDIT mode (editing)

— Exporting/importing samples

Exporting sample banks

1 In the slot selection, press     to select the bank you want to export.

2 Press .

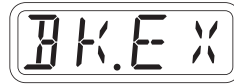

3 Set your PC to receive MIDI data.







4 Press  .

This starts sample data transmission.

The step LEDs will show the progress. When finished, DONE will appear on the display.

Importing sample banks



1 In the slot selection, press     to select the bank you want to export.

2 Press .



3 Start transmitting data from the transmitting device.



4 When BK.SV is shown, press  .



Step sequencer overview

Overview

The Lofi-12 step sequencer can play **multiple steps** in order (a sequence) with performance and parameter data.



Steps contain **note data** and **parameter data**.

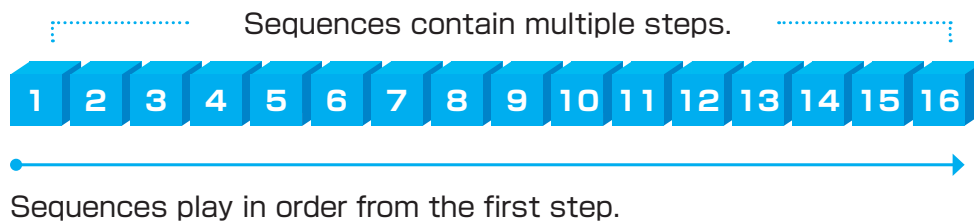

Lofi-12 step sequencer features

The sequencer in the Lofi-12 has the following features.

Three input methods

Step recording

Record notes to each step with the sequencer stopped

Real-time recording

Record notes to steps by playing the keyboard

Direct recording

Record notes to steps directly during sequencer playback

Flexible sequencing

Sequences with up to 64 steps

The number of steps can be set from 1 – 64 as desired for each track

Support for various note lengths

The length of each step can be set from 1/32nd note to 1 bar.

Creating sequences – Preparation

Selecting tracks and setting sounds

1 Press one  button to select the track for sequence creation.

2 Turn  **BANK** and  **SAMPLE** to select the sound to use.



- The LIVEN Lofi-12 can generate a maximum of 10 notes simultaneously (10-voice polyphony).
 - If the maximum polyphony is exceeded, notes will be turned off starting with notes on the lowest priority track. (The track priority is from 4 to 1 in order. However, sounds that are being released will be turned off first in track priority order.)
 - The LIVEN Lofi-12 includes 8 banks of 16 sounds, allowing selection of up to 128 sounds.
-

Creating sequences - Settings

Setting the note length of one step

1 Press  + .

2 Use  VALUE to select the note length.

VALUE

Note	
1/1	Whole note
1/2	Half note
1/.4	Dotted quarter note
1/4	Quarter note
1/.8	Dotted 8th note
1/2T	Half note triplet
1/8	8th note
1/.16	Dotted 16th note
1/4T	Quarter note triplet
1/16	16th note
1/32	32nd note

Changing the sequence length

1 Press  + .

2 Use  VALUE to set the sequence length.





VALUE

Length
1 - 64 (steps)

Creating sequences – Step recording

Using step recording, sequences can be created carefully while playback is stopped.

Basic operations

- 1 When stopped, press  (lights red).
- 2 Press  –  at the step where you want to input a note.
The LED for the current step will blink. The LEDs for steps that already have notes will light.
- 3 Play a note on the keyboard to input it at the step.
Press the same note again on the keyboard to remove it from the step.
Repeat steps 2 – 3 to create the sequence.
- 4 Press  to end step recording.

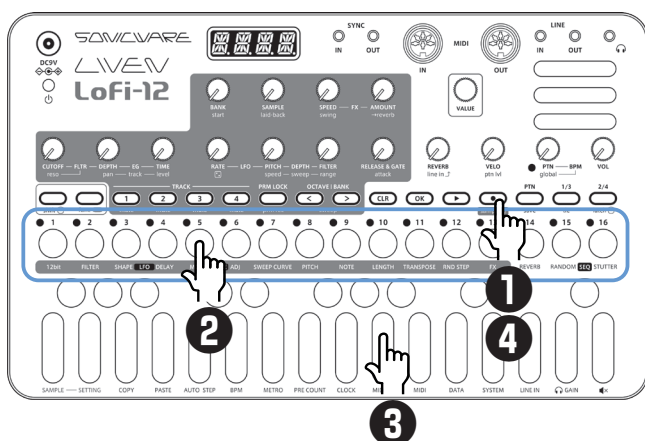

Creating sequences - Step recording

Selecting steps 17 and higher

After procedure number one, press $\frac{1}{3}$ and $\frac{2}{4}$ to select steps 17 and higher.

To select steps 1-16, press the $\frac{1}{3}$ button.



To select steps 17-32, press the $\frac{2}{4}$ button.



To select steps 33-48, press the $\frac{1}{3}$ button twice.



To select steps 49-64, press the $\frac{2}{4}$ button twice.



- In procedure 2, pressing $\frac{1}{3}$ - $\frac{1}{6}$ will cause the stored note to sound continuously. This is by design.
 - $\frac{1}{6}$ VALUE can also be used to move between steps.
 - Page buttons are enabled or disabled according to the length of the sequence.
-

Creating sequences - Step recording

Clearing steps

1 Press  +  - .

During step recording, only the note information for that step will be cleared.

Copying steps

1 During step recording, press  -  to select the step to copy.

2 Press  + .



3 Press  -  to select the paste destination step.

4 Press  + .



The note and parameter lock data from the copy source step will be pasted to the destination step.



-
- Data for ties cannot be copied.
-

Automatically advancing steps during step recording (Auto Step mode)



In step recording mode, the step can be advanced automatically each time a key of the keyboard is pressed.

1 Press  +  to turn this mode on/off.





Creating sequences - Step recording

Tied-notes (long sounds) can be input with the Lofi-12.

Enabling tied-note (long sound) input

- 1 Press  +  .
The button will light red, and tied-note input will be enabled.

Inputting tied-notes (long sounds)

- 1 When stopped, press  (lights red) to start step recording.
- 2 Press  -  at the step where you want to start note input.
- 3 Press and hold a key on the keyboard.
- 4 Press  -  at the step where you want to stop the note.
This inputs a tied-note from the starting step to the stopping step.

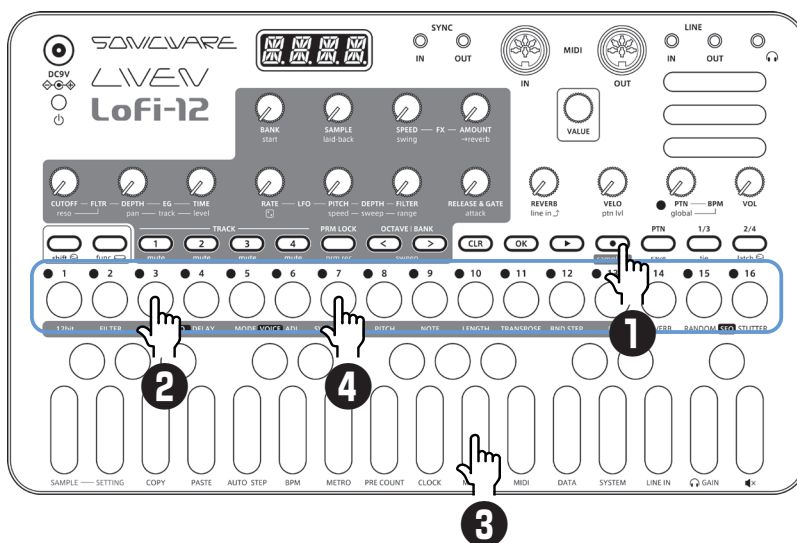

In the example above, a note (A) is input that starts on step 3 and ends on step 7.





- By pressing  and  during procedure 4, tied-notes that span pages can be input.

Creating sequences - Real-time recording

Sequences can be created in real time while playing the keyboard.



Basic operations

- 1 After pressing , press .
- 2 The pattern will start playing, so play the keyboard when you want to input notes.

Clearing notes

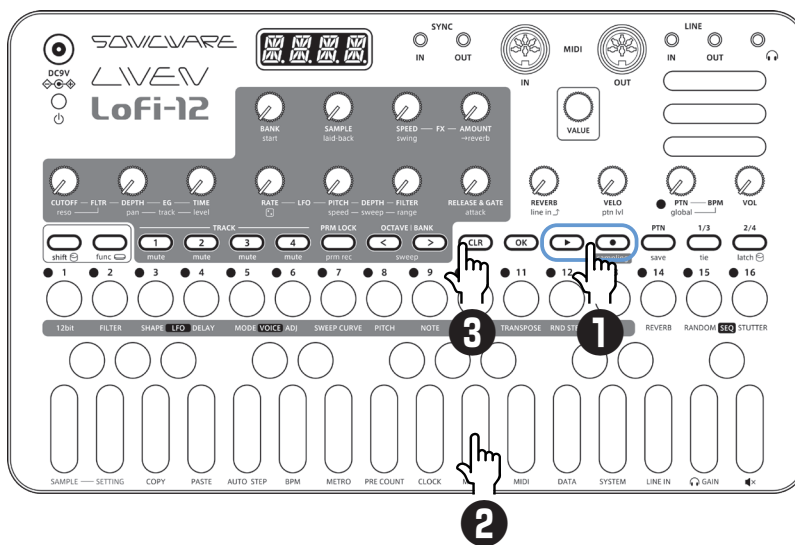
- 3 Press  at the time when you want to clear notes. Notes will be cleared while this is being pressed.



- By pressing  +  to enable the input of tied-notes, long notes that span steps can be input.

Creating sequences - Real-time recording

Setting the metronome

1 Press  +  to select MTRO.



2 Use  VALUE to adjust the metronome volume.

VALUE

Metronome
0 - 15

Setting a pre-count

1 Press  +  to select PR.CT.



2 Use  VALUE to change the pre-count.

VALUE

Metronome
OFF, 1 - 8



- When a pre-count is set, recording and playback will start after the pre-count.
-

Creating sequences - Direct recording

With direct recording, notes can be input on steps directly when both stopped and playing back.

This is particularly suitable for building up sequences while performing by directly inputting notes during playback.

Basic operations

- 1 Press and hold $\circ - 16$ for the position where you want to input a note
- 2 Play a note on the keyboard to input it at the step.
Notes can also be input if procedures 1 and 2 are done in reverse order.

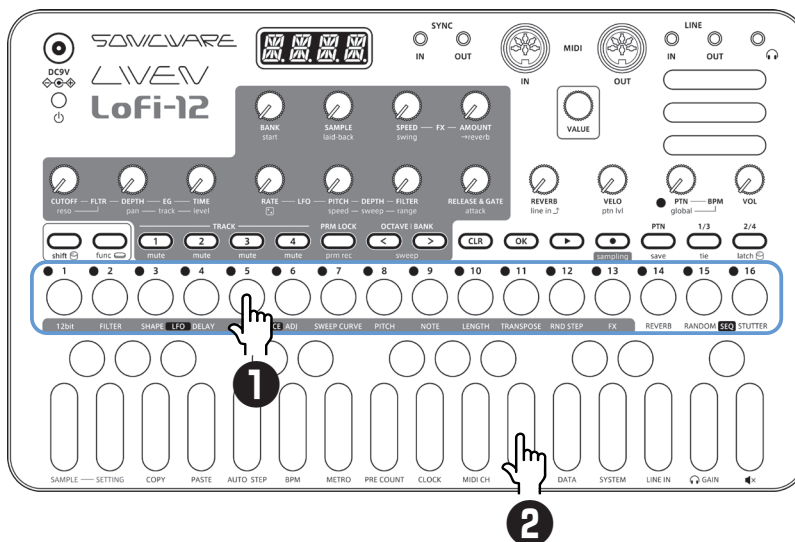

Creating sequences - Direct recording



- By pressing $\frac{1}{3}$ and $\frac{2}{4}$ before procedure 1, pages with steps 17 and higher can be selected.

To select steps 1-16, press the $\frac{1}{3}$ button.



To select steps 17-32, press the $\frac{2}{4}$ button.



To select steps 33-48, press the $\frac{1}{3}$ button twice.



To select steps 49-64, press the $\frac{2}{4}$ button twice.



- During playback, pressing $\frac{1}{3}$ or $\frac{2}{4}$ will lock the page shown.
Press  to unlock the page.

Creating sequences - Groove settings

The Lofi-12 includes a swing function for creating offset rhythms and a laid-back function for delaying the timing of sample sounds.

Setting the swing

- 1 Turn $\text{shift} + \text{swing}$ to adjust it.
Every even step (2nd, 4th, 6th, etc.) will be delayed.

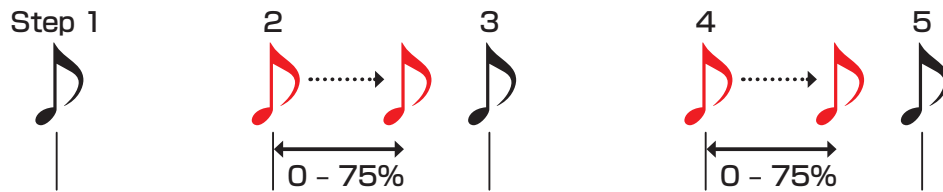

This setting can be made separately for each track.

Setting the laid-back function

- 1 Turn $\text{shift} + \text{laid-back}$ to adjust it.
This delays the timings of entire samples for the selected track.

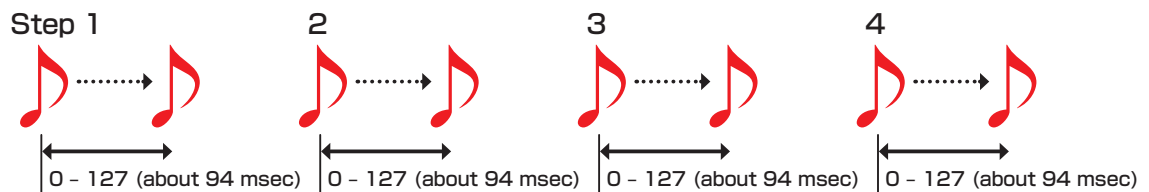

- The timings of sounds can be changed independently for each step using the parameter locking function.
The sound locking function can be used to create a drum track that has multiple samples on a single track, and these functions can be used to freely set the timing of bass drum and snare sounds, for example.

Parameter locking

The Lofi-12 has a **parameter locking** function that can record knob operations to steps.

This allows sounds to be changed over time and is useful for creating patterns with great expressiveness.

Parameter locking data can be input in the following three ways.

Direct input

Turn knobs while pressing $\text{1} - \text{16}$ in this fundamental method of direct input.

Real-time input

Record the operation of knobs during playback in real-time in this method.



Sound locking input

When recording notes to steps by pressing keys on the keyboard, the state of the sound currently playing is simultaneously recorded to the step as parameter lock data in this input method.

Basic parameter locking operations

Turning parameter locking on

- 1 Press PRM LOCK .
Pressing PRM LOCK cycles through the following states.

	Parameter locking off	Parameters do not change automatically
	Parameter locking on	Parameters change automatically based on parameter lock data
	Sound locking on	Sound lock recording enabled (→ P. 62)

Clearing parameter lock data



- 1 Press $\text{CLR} + \text{PRM LOCK}$.
This clears parameter lock data.

Parameter locking – Direct input



Turning parameter locking on

1 Press  (lights green).

Recording knob operations

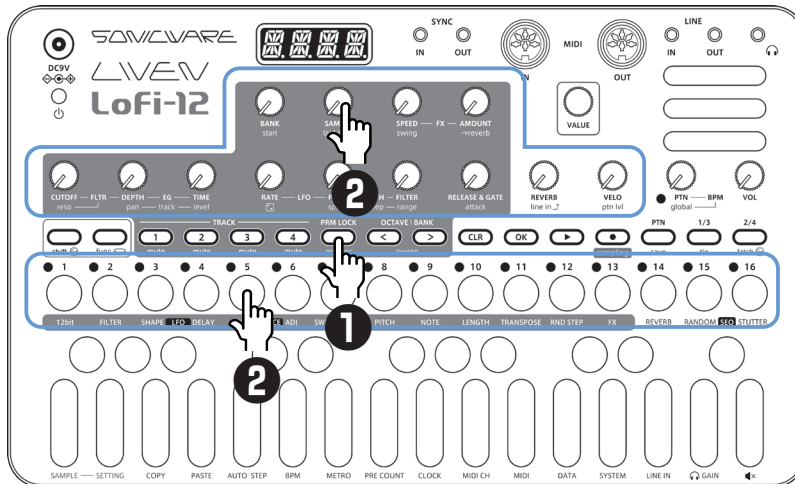



2 While pressing  - , turn  knobs.



- By pressing  and  before procedure 2, pages with steps 17 and higher can be selected.
- Parameter locking cannot be used on REVERB, line in ↑, ptn level, PTN BPM, global BPM and VOL.

Parameter locking – Real-time input

Inputting in real time (parameter recording)

- 1 Press  +  (lights red).
- 2 Press  to play the pattern.
- 3 Turn  knobs and record the changes.
- 4 Press  , making it light green, to end real-time input.

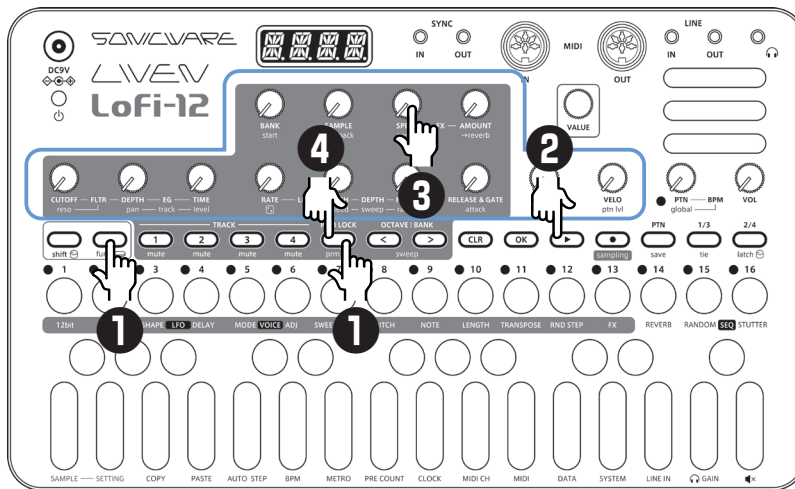

Parameter locking - Sound locking input

Turning sound locking on

- 1 Press **PRM LOCK** twice (lights orange).

Recording note input and parameter lock data at the same time

- 2 While pressing **1 - 16**, play the keyboard.

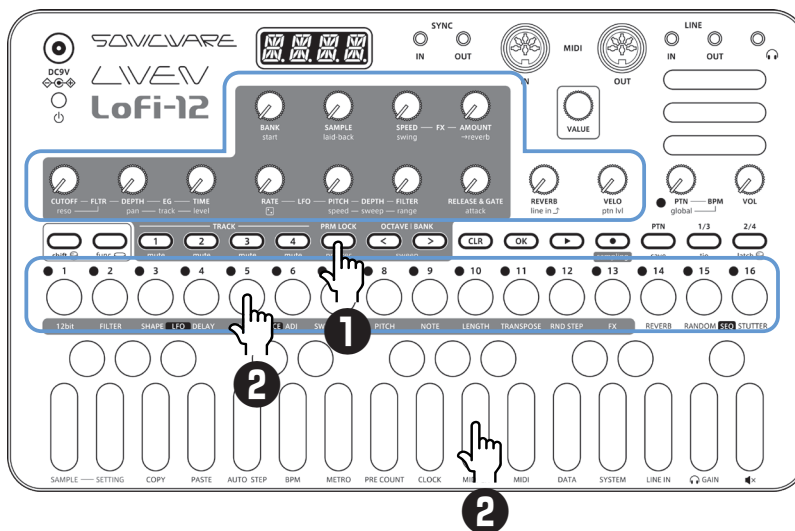

- In procedure 2, direct recording is used for note input. The sound locking function can also be used with step recording and real-time recording in the same manner.
- The parameter lock data that is recorded using the sound locking function includes BANK, SAMPLE, start, RELEASE & GATE and attack.

Sequence effects

The Lofi-12 has sequence effect functions, including **Dice** that sets the probability of notes sounding, **Random** that can randomize phrases, and **Stutter** that repeats playback of pressed steps.

Random

1 Press  + .

When this is on, a randomized sequence will be played back

Press  +  again to turn the random function off.

Random settings

The smallest unit used for randomization during random playback can be set (for example, 1 step or 4 steps).

1 Press  + , and use  to adjust.

VALUE

Random step unit
OFF, 1, 2, 4, 8, 16 (steps)
If set to OFF, randomization will not occur even if the random playback function is on.

The random on/off setting is saved with the pattern, but random unit settings can be saved per track.

Dice

1 Turn  + .

The probability of a note sounding can be set from 25 - 100%.





- The probability of notes sounding can be set independently for each step using the parameter locking function.

Sequence effects

Stutter

1 Press  +  .
Turning this on enables stutter mode.

2 Press  -  .
Only the pressed steps will be played.

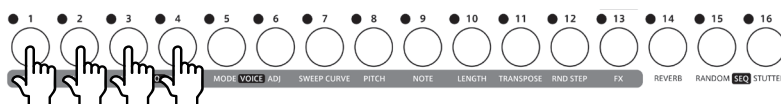

Press  +  again to turn stutter mode off.

Deleting sequences

Clearing steps

- 1 Press + . The note and parameter lock data from that step will be cleared.



- While pressing , steps that have parameter lock data blink red.
 - When recording notes (lit red), only note data will be cleared.
 - When parameter recording (lit red), only parameter lock data will be cleared.
 - Normally, when and buttons are lit red, both note and parameter data will be cleared.
-

Clearing all note data in a sequence

- 1 Press + for the track with the sequence to be cleared.

- 2 Use to select NOTE, and press .
This clears all notes on all steps of the sequence.

Restoring only track sounds to the last saved state

- 1 Press + for the track with the sound to be restored.

- 2 Turn to select SND, and press .
-





Copying tracks

Copying tracks

1 Press     to select the track of the pattern to be copied.

2 Press  + .



3 Press     to select the track for the pattern to be pasted.

4 Press  + .



Pattern saving

Sequences created on every track can be saved as patterns.

Saving patterns

1 Press  + .



2 Press .
DONE will appear, and it will be saved.





Changing the save destination or **copying the pattern**

1 Press  + .

2 Use  to select the save destination bank.



3  -  to select the save destination pattern.
DONE will appear, and it will be saved.



- In procedure 2,  VALUE can also be used to select the save destination (execute with ).
 - Press  during a procedure to cancel it.
-

Initializing patterns

1 Select the pattern to be initialized.
(→ P. 15)

2 Press  + .
CLR will be shown, and pattern settings along with note and parameter lock data will all be cleared.



3 Save the pattern.



Pattern renaming

Renaming patterns

- 1 Press  +  multiple times to select P.N.ED (**p**attern **n**ame **e**dit**ing**).



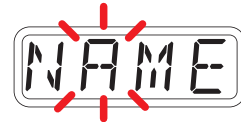

- 2 Use  VALUE to select the pattern for renaming, and press .

- 3 Use  and  to move the cursor left and right, and turn  VALUE to select characters.



Cursor position blinks

- 4 Press .
- This saves the name and returns to pattern selection.
- To rename other patterns, repeat from procedure 2.
- To end renaming, press .



Tempo overview

The Lofi-12 has two BPM modes.

Pattern BPM mode

Whenever a different pattern is selected, the BPM is reset using the tempo saved in that pattern.

Global BPM mode

The current global BPM value will continue to be used even when a different pattern is selected.

Select global BPM mode to maintain a consistent tempo during the jam session. Use pattern BPM mode when you want the tempo to change with each pattern.

Setting the BPM mode

1 Press  + .

2 Use  VALUE to select the BPM mode.



BPM	
BPM mode	
PTN	Pattern BPM mode
GLBL	Global BPM mode

Setting the pattern BPM

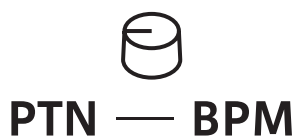

1 Turn  PTN — BPM.



Pattern BPM
40 - 250
When the tempo is shown on the display,  VALUE can be turned to change it in 0.1-beat increments.

Tempo overview

Setting the global BPM

1 Press  +  global — BPM.

 +  global — BPM

Global BPM
40 - 250
When the tempo is shown on the display,  VALUE can be turned to change it in 0.1-beat increments.

Clock synchronization with external devices — Clock settings

Overview

The Lofi-12 has the following synchronization capabilities.

SYNC

Use the SYNC IN/OUT jacks to connect and synchronize with devices that support SYNC (including the Korg Volca series).

MIDI

Use the MIDI IN/OUT jacks to connect and synchronize with devices that support MIDI.

Audio Sync

Use the LINE IN and headphone jacks to connect and synchronize with devices that support Audio Sync (including the Teenage Engineering Pocket Operator series).

When using Audio Sync, the audio exchanged will be mono.

The Lofi-12 can act as a clock master or receive clock from an external device.

Clock synchronization with external devices — Clock settings

Setting the clock source

When set to INT (internal), the Lofi-12 acts as a clock master. When not set to INT, the external device will be treated as the clock master.

1 Press  +  to select SRC.



2 Turn  VALUE to set the clock source.

VALUE

Clock Source	
INT	Use internal clock of LIVEN Lofi-12
MIDI	Use clock from MIDI IN
SYNC	Use clock from SYNC IN
LINE	Use clock from LINE IN

Setting Audio Sync output

Audio Sync output uses the headphone jack. For this purpose, make the following setting to use Audio Sync output.

1 Press  +  and select A.OUT.



2 Turn  VALUE to select ON.



- The sync signal will be output from the left channel and a mono mix of the audio will be output from the right channel of the headphone jack.

Clock synchronization with external devices — Clock settings

Setting SYNC IN polarity

1 Press  +  and select S.I.P.O.



2 Turn  VALUE to set the polarity.

VALUE

Polarity - Sync In	
FALL	Synchronize with falling of sync signal
RISE	Synchronize with rising of sync signal

Setting SYNC OUT polarity

1 Press  +  and select S.O.P.O.



2 Turn  VALUE to set the polarity.

VALUE

Polarity - Sync In	
FALL	Synchronize with falling of sync signal
RISE	Synchronize with rising of sync signal



- See P. 78 for details about setting MIDI clock.

Clock synchronization with external devices — Connection examples

Lofi-12 as clock master

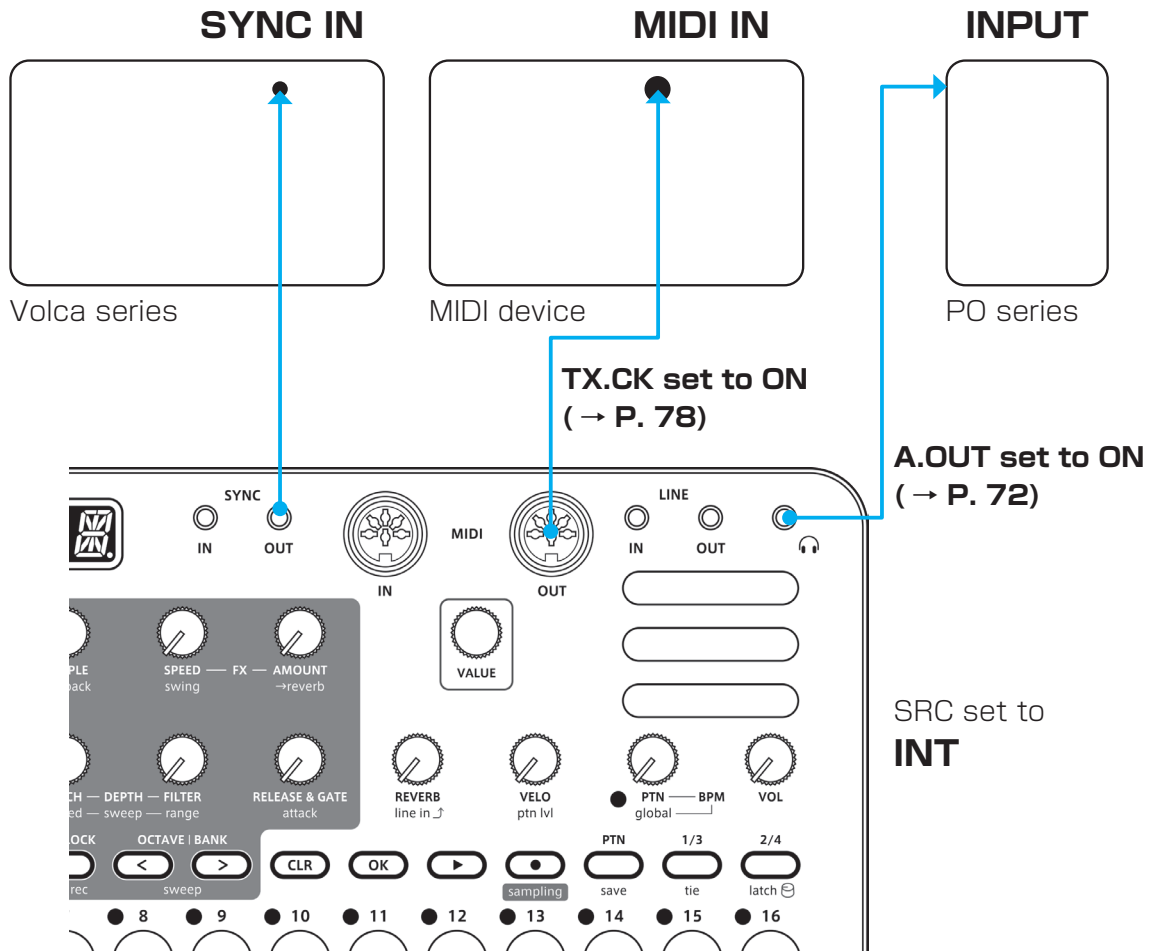

Clock synchronization with external devices — Connection examples

External device as clock master

Make only one device the clock master

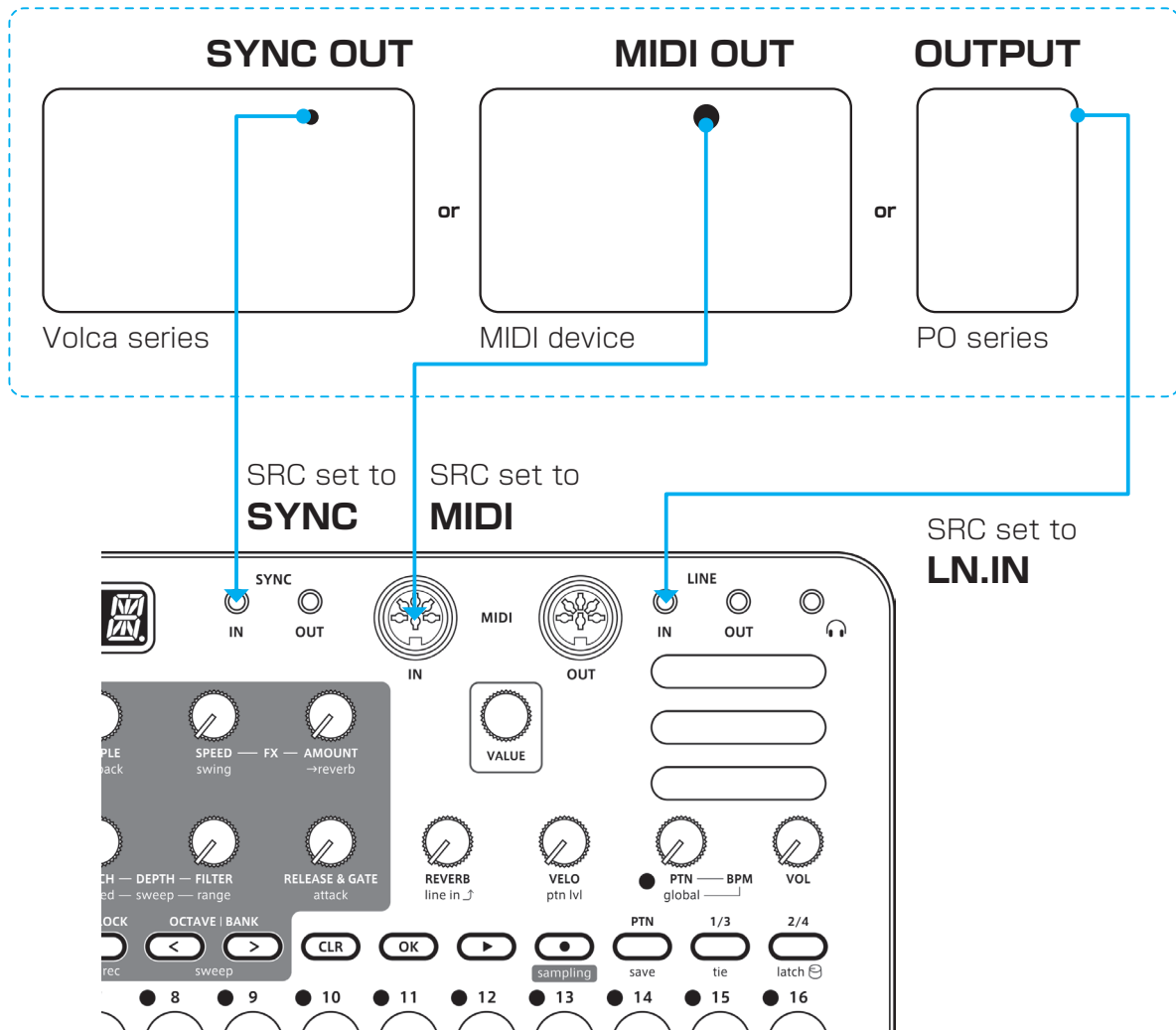

Clock synchronization with external devices — Connection examples

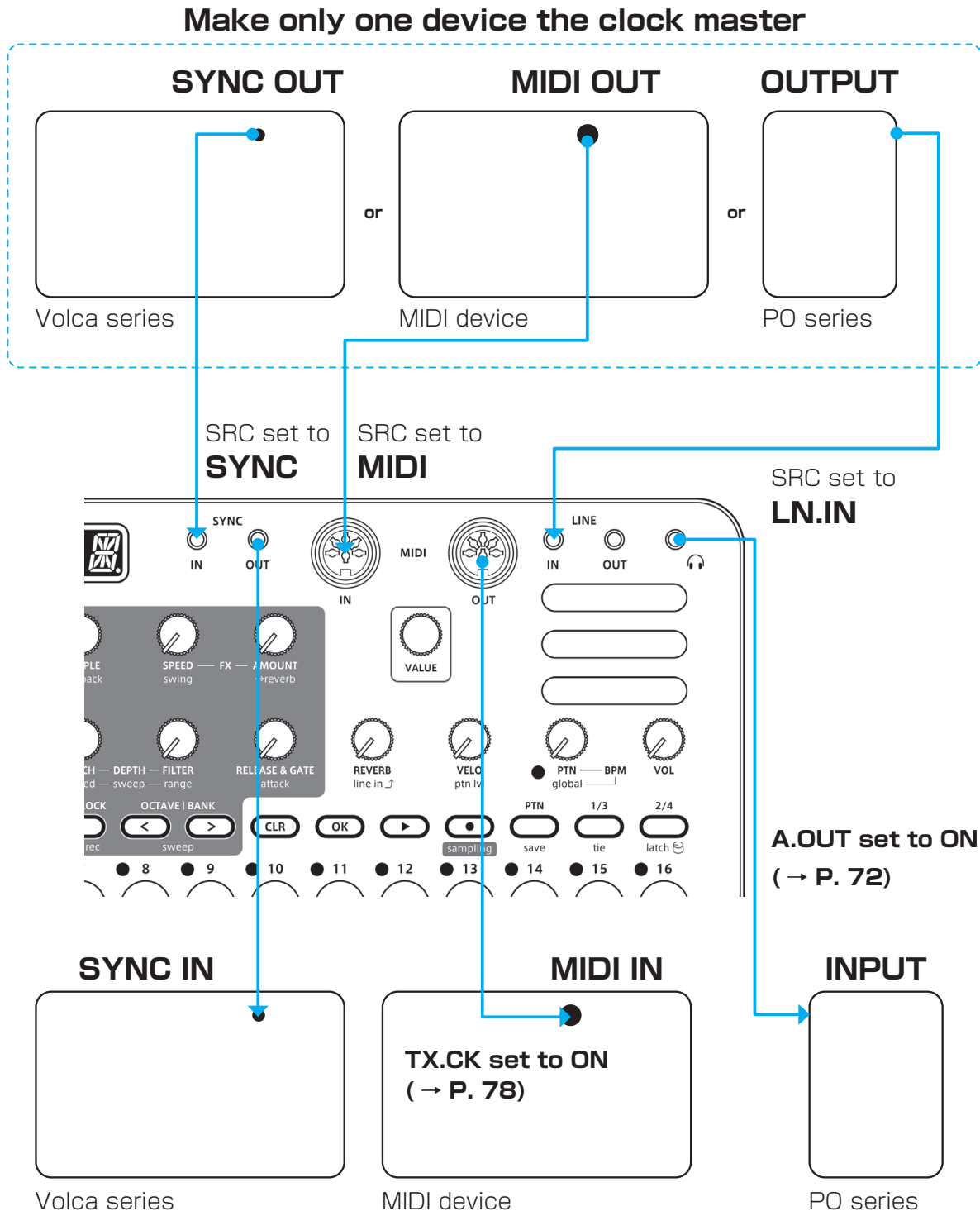

Bridging clock signals to a different connector from an external device acting as the clock master



Using the bridging function, it is possible to synchronize devices with different connectors. For example, a Pocket Operator acting as a clock master can be used to synchronize a Volca or MIDI device connected to the Lofi-12.

MIDI

Setting channels for transmitting and receiving MIDI

- 1 Press  + , and select the track for which you want to set the MIDI channel.

T 1.CH

}

- 2 Turn  VALUE to set the channel.

T 4.CH



VALUE

MIDI Channel
OFF, CH.01 - CH.16

Setting the MIDI channel for pattern parameters

- 1 Press  + , and select PT.CH.

PT.CH

- 2 Turn  VALUE to set the channel.



VALUE

MIDI Channel
OFF, CH.01 - CH.16

Setting the MIDI channel for accessing the selected track (automatic channel)

- 1 Press  + , and select AT.CH.

AT.CH

- 2 Turn  VALUE to set the channel.

VALUE

MIDI Channel
OFF, CH.01 - CH.16

MIDI

Setting the MIDI channel used to output keyboard playing

1 Press  +  and select O.CH.



2 Turn  VALUE to set it.



MIDI Channel
TRCK (track), AUTO

Turning control change transmission on/off

1 Press  +  and select TX.CC.



2 Turn  VALUE to set it to on/off.



Control Change
ON, OFF



- Control change reception is always enabled.

Turning MIDI clock output on/off

1 Press  +  and select TX.CK.



2 Turn  VALUE to set it to on/off.



MIDI Clock
ON, OFF

MIDI

Setting MIDI OUT

1 Press  +  and select M.OUT.



2 Turn  VALUE to set MIDI OUT.



VALUE

MIDI OUT
OUT, THRU

Setting MIDI command transmitting and receiving

1 Press  +  and select M.CMD.



2 Turn  VALUE to set MIDI command transmitting and receiving.



VALUE

MIDI Commands	
OFF	Neither transmit nor receive
R	Only receive
T	Only transmit
R,T	Transmit and receive

Turning active sensing transmission on/off

1 Press  +  and select TX.AS.



2 Turn  VALUE to set it to on/off.

VALUE

Active Sensing - Transmit
ON, OFF

MIDI

Turning on/off active sensing reception

1 Press  +  and select RX.AS.

RX.AS

2 Turn  VALUE to set it to on/off.

VALUE

Active Sensing - Receive

ON, OFF

Setting the channel for transmitting and receiving program changes

1 Press  +  and select PC.CH.

PC.CH

2 Turn  VALUE to set the program change channel.

VALUE

Program Change - Channel

AUTO, CH.01 - CH.16

Turning on/off program change transmission

1 Press  +  and select TX.PC.

TX.PC

2 Turn  VALUE to set it to on/off.

VALUE

Program Change - Transmit

ON, OFF

MIDI

Turning on/off program change reception

1 Press  +  and select RX.PC.



2 Turn  VALUE to set it to on/off.



VALUE

Program Change - Receive
ON, OFF

Exporting/importing user data

Connecting

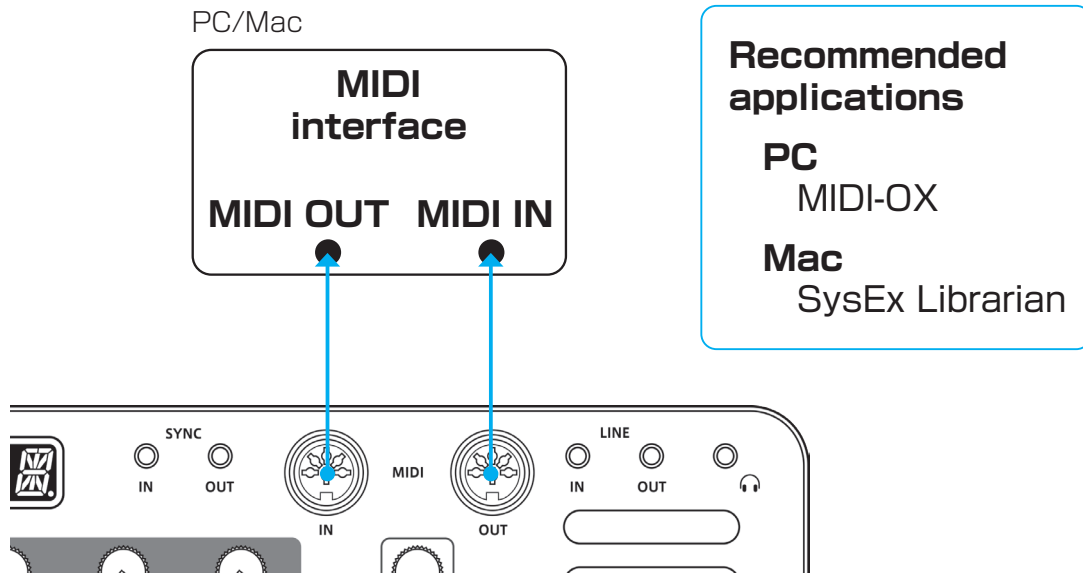
- Exporting/importing to/from a PC/Mac



Connecting

- Exporting/importing to/from another Lofi-12

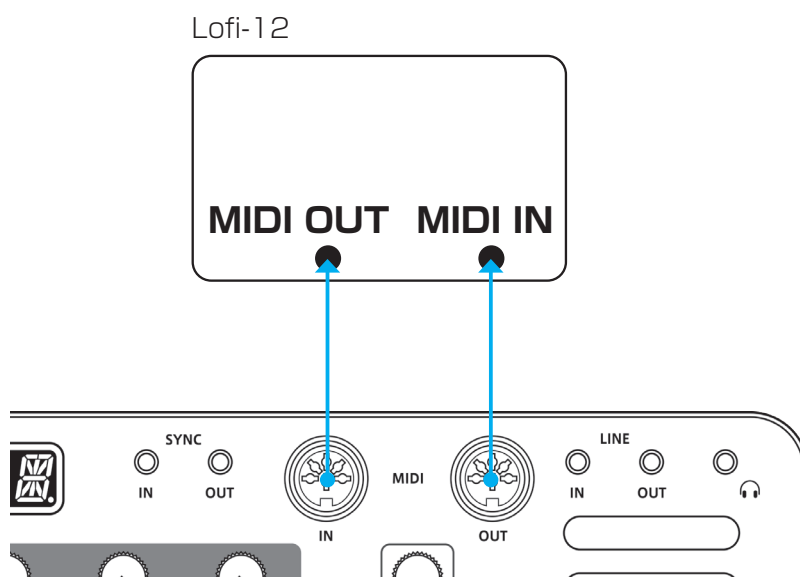

Exporting/importing user data

Exporting a single pattern

1 Select the pattern you want to export. (→ P. 15)

2 Press  +  and select P.EXP.



3 Set your PC to receive MIDI data.



4 Press .



-
- Press  to cancel.
-

Importing a single pattern

1 Put the unit into regular mode, and start transmitting data from the transmitting device.



-
- The received pattern will not be saved automatically. Save the pattern as necessary. (→ P. 67)
-

Exporting/importing user data

Backing up all user data at once



1 Press  + the **POWER** switch to turn on the Lofi-12.

2 Turn  **VALUE** to select EXPT.



3 Press .



-
- The step LEDs show the progress. (They light from ① in order. Transmission is complete when ① - ⑥ have all lit.)
 - Press  to cancel.
 - The size of the backup data is 69,908 messages - 16.7MB.
 - If the size of the data is different, the backup might have failed. If this occurs, before step ③, while pressing , turn  **VALUE** to increase the transmission interval. (The default value is 0.)
-

Exporting/importing user data

Restoring (importing) user data

1 Press  + **the POWER switch** to turn on the Lofi-12.





2 Turn  **VALUE** to select IMPT.



3 Press . This makes the unit ready to receive data.
Start exporting from the sending device.

4 When SAVE appears on the display after receiving completes, press  to restore (load) the received data.



-
- The step LEDs show the progress. (They light from  in order. Transmission is complete when  -  have all lit.)
 - Press  to cancel.
-

System settings

Setting the battery type

1 Press  +  to select BATT.



2 Turn  VALUE to select the battery type.

VALUE

Battery	
ALKL	Alkaline dry cell
NIMH	Nickel-metal hydride rechargeable
LTHM	Lithium dry cell



- Please set this correctly because it effects operation time.
- The remaining charge shown could be higher than the actual amount depending on the type of rechargeable battery.

Setting the automatic power down function

1 Press  +  and select A.PWR.



2 Turn  VALUE to select the automatic power down time.

VALUE

Automatic power down time	
OFF	Automatic power down is disabled.
0.5H	Power will turn off automatically after 30 minutes without operation.
1H	Power will turn off automatically after 1 hour without operation.
3H	Power will turn off automatically after 3 hours without operation.
6H	Power will turn off automatically after 6 hours without operation.

System settings

Setting the headphone gain

- 1 Press  + .

Headphone Gain	
<i>LOUD</i>	Louder output
<i>NORM</i>	Factory default
<i>SOFT</i>	Quieter output

Setting the master tuning

- 1 Press  +  to select TUNE.

TUNE



- 2 Turn  to set the master tuning.



VALUE

Master Tuning
- 75 - 0 - +75 (cents)

System settings

Setting knob movement behavior

- 1 Press  +  to set whether or not latching is used for knob operation.

Latching		
	Jump	When a knob is moved, the parameter changes immediately.
	Latch	The knob does not affect the parameter value until its position reaches that value. Then, the value follows the knob.



- When set to Latch, the dots on the display will be animated to show how much the knob position and parameter value differs to the left or right.

The dots will appear to flow to the left when the parameter value is lower than the knob position and to the right when the value is higher than the position. The flow will be faster for higher values.

System settings

Restoring to factory default settings (factory reset)

- 1 Press and hold  + **the POWER switch** to turn on the Lofi-12.



- 2 Press .
The step LEDs will show the progress.
When finished, OK will appear on the display.









- Press  to cancel.
- This will not restore sample waveform data to the factory default. To restore the sample waveform data, download it from the SONICWARE website and import it.

Checking the system versions

- 1 Press and hold  + **the POWER switch** to turn on the Lofi-12.



- 2 Press ,  and  to check the versions.

Firmware Versions		
		System version
		Boot version
		Preset version

Major version

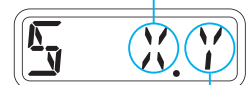

Minor version



- Press the same ,  or  again to show the build number.

System settings

Updating the firmware

- 1 Press and hold  + **the POWER switch** to turn on the Lofi-12.



- 2 Transmit the firmware (Sys Ex data) from a PC/Mac.



- The step LEDs show the progress of data transmission. (They light from 1 in order. Transmission is complete when 1 - 16 have all lit.)
-

- 3 After transmission completes, press  to execute the update.



- If the update occurred properly, OK will be shown. (If a problem occurred, an error code will be shown.)
-

- 4 Restart the unit.



- Use new batteries or an AC adapter.
 - Never interrupt the power during a firmware update.
 - Press  to cancel the update and start up normally.
-

System settings

Error codes

<i>ER.10</i>	System error
<i>ER.11</i>	Low battery
<i>ER.20</i>	Data receiving error
<i>ER.21</i>	Invalid data
<i>ER.22</i>	No need to update (Boot)
<i>ER.30</i>	Update Failed

Appendix

Figure 1. Sound architecture

